

## Pressure Sensors

Low-Cost, Stainless Steel, Isolated Sensors

*19 mm Series*

### FEATURES

- Low cost
- Rugged, isolated stainless steel package
- Small size
- Reliable semiconductor technology
- Calibrated and temperature compensated
- Absolute and gage pressures
- Vacuum compatible, isolated sensors
- 0 psi to 3 psi to, 0 psi to 500 psi

### TYPICAL APPLICATIONS

- Industrial controls
- Process control systems
- Industrial automation and flow control
- Pressure calibrators



Honeywell's stainless steel 19C, 19U, and 19 Vacuum Gage Series sensors were developed for pressure applications that involve measurement of hostile media in harsh environments compatible with 316 stainless steel. The special Vacuum Gage Series sensors are specifically designed for applications that can be exposed to vacuum.

The 19C Series are calibrated and temperature compensated. They are available for use with either a constant voltage or current source. They feature a variety of pressure connections to allow use in a wide range of OEM (Original Equipment Manufacturer) equipment. The 19U Series is uncompensated for applications that use their own specialized circuit designs.

The 19C and 19U Series sensors are rugged and reliable transducers for use in a wide variety of pressure sensing applications where corrosive liquids or gases are monitored.

### 19C, 19U, AND 19 VACUUM GAGE EQUIVALENT CIRCUIT

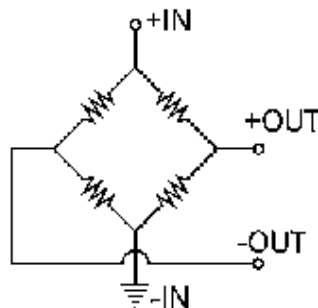

### WARNING

#### PERSONAL INJURY

DO NOT USE these products as safety or emergency stop devices or in any other application where failure of the product could result in personal injury.

**Failure to comply with these instructions could result in death or serious injury.**

### WARNING

#### MISUSE OF DOCUMENTATION

- The information presented in this product sheet is for reference only. Do not use this document as a product installation guide.
- Complete installation, operation, and maintenance information is provided in the instructions supplied with each product.

**Failure to comply with these instructions could result in death or serious injury.**

# Pressure Sensors

Low-Cost, Stainless Steel, Isolated Sensors

*19 mm Series*

## PRESSURE SENSOR CHARACTERISTICS – ALL DEVICES

Environmental specifications	
Compensated temperature range	0 °C to 82 °C [32 °F to 180 °F]
Operating temperature range	-40 °C to 125 °C [-40 °F to 257 °F]
Storage temperature range	-40 °C to 125 °C [-40 °F to 257 °F]
Vibration	10 G at 20 Hz to 2000 Hz
Shock	100 G for 11 ms
Life	1 million cycles min.
Insulation resistance	100 mΩ at 50 Vdc
Maximum ratings	
Voltage version “K”	Supply voltage $V_s = +15$ Vdc
Voltage version “L”	Supply current $I_s = +2.0$ mA

## PRESSURE RANGE SPECIFICATIONS (19C, 19U)

Catalog Listing	Pressure range	Proof pressure <sup>(7)</sup>	Burst pressure <sup>(8)</sup>
19(C,U) 003P G (1...9) (K/L)	0 psig to 3 psig	9 psig	15 psig
19(C,U) 005P G (1...9) (K/L)	0 psig to 5 psig	15 psig	25 psig
19(C,U) 010P G (1...9) (K/L)	0 psig to 10 psig	30 psig	50 psig
19(C,U) 015P (A,G,V) (1...9) (K/L)	0 psi to 15 psi	45 psi	75 psi
19(C,U) 030P (A,G,V) (1...9) (K/L)	0 psi to 30 psi	90 psi	150 psi
19(C,U) 050P (A,G,V) (1...9) (K/L)	0 psi to 50 psi	150 psi	250 psi
19(C,U) 100P (A,G,V) (1...9) (K/L)	0 psi to 100 psi	300 psi	500 psi
19(C,U) 200P (A,G,V) (1...9) (K/L)	0 psi to 200 psi	600 psi	1000 psi
19(C,U) 300P (A,G,V) (1...9) (K/L)	0 psi to 300 psi	900 psi	1500 psi
19(C,U) 500P (A,G,V) (1...9) (K/L)	0 psi to 500 psi	1200 psi	2400 psi

Notes:

- The maximum pressure that can be applied without changing the transducer's performance or accuracy.
- The maximum pressure that can be applied to a transducer without rupture of either the sensing element or transducer case.

## 19C SERIES PERFORMANCE CHARACTERISTICS <sup>(1)</sup>

Characteristic	Minimum	Typical	Maximum	Unit
Zero pressure offset	-2	0	2	mV
Full-scale span <sup>(2)</sup>	98	100	102	mV
Full-scale span (3 psi and 5 psi “K” units only) <sup>(2)</sup>	48	50	52	mV
Pressure non-linearity <sup>(3)</sup>	–	±0.1	±0.25	%FSS
Pressure hysteresis <sup>(3)</sup>	–	±0.015	±0.030	%FSS
Repeatability	–	±0.010	±0.030	%FSS
Temp. effect on span <sup>(4)</sup>	–	±0.5	±1.0	%FSS
Temp. effect on offset <sup>(4)</sup>	–	±0.5	±1.0	%FSS
Temp. effect on span (0 psi to 3 psi and 0 psi to 5 psi only) <sup>(4)</sup>	–	–	±2.0	%FSS
Temp. effect on offset (0 psi to 3 psi and 0 psi to 5 psi only) <sup>(4)</sup>	–	–	±2.0	%FSS
Thermal hysteresis (0 °C to 82 °C [32 °F to 180 °F])	–	±0.1	±0.3	%FSS
Long-term stability of offset and span <sup>(5)</sup>	–	±0.1	±0.3	%FSS
Response time <sup>(6)</sup>	–	0.1	–	ms
Common mode voltage (voltage version “K”) <sup>(9)</sup>	0.5	1.3	2.0	Vdc
Input impedance (current version “L”)	2.0	4.5	8.0	kΩ
Input impedance (voltage version “K”)	8.0	25	50	kΩ
Output resistance	3.0	4.5	6.0	kΩ

# Pressure Sensors

Low-Cost, Stainless Steel, Isolated Sensors

19 mm Series

## 19U SERIES PERFORMANCE CHARACTERISTICS <sup>(1)</sup>

Characteristic	Minimum	Typical	Maximum	Unit
Zero pressure offset	-7.5	1.0	7.5	mV/V
Full-scale span <sup>(2)</sup>	35	40	60	mV/V
Full-scale span (3 psi and 5 psi only) <sup>(2)</sup>	20	30	40	mV/V
Pressure non-linearity <sup>(3)</sup>	–	±0.1	±0.25	%FSS
Pressure hysteresis <sup>(3)</sup>	–	±0.015	±0.030	%FSS
Repeatability	–	±0.010	±0.030	%FSS
Temp. coefficient of resistance <sup>(10)</sup> (0 °C to 82 °C [32 °F to 180 °F])	2700	3420	4500	ppm/°C
Temp. coefficient of offset <sup>(10)</sup> (0 °C to 82 °C [32 °F to 180 °F])	–	30	–	µV/V/°C
Temp. coefficient of span <sup>(10)</sup> (0 °C to 82 °C [32 °F to 180 °F])	360	720	1260	ppm/°C
Thermal hysteresis (0 °C to 82 °C [32 °F to 180 °F])	–	±0.1	±0.3	%FSS
Long-term stability of offset and span <sup>(5)</sup>	–	±0.1	±0.3	%FSS
Response time <sup>(6)</sup>	–	±0.1	–	ms
Input resistance	4.00	4.75	6.0	kΩ
Output resistance	4.00	4.75	6.0	kΩ

## 19C VACUUM GAGE COMPENSATED SERIES PERFORMANCE CHARACTERISTICS <sup>(1)</sup>

Characteristic	Minimum	Typical	Maximum	Unit
Zero pressure offset (at 0 psig)	-2	0	2	mV
Full-scale span <sup>(2)</sup> (0 psig to positive full-scale)	98	100	102	mV
Pressure non-linearity <sup>(3)</sup>	–	±0.1	±0.25	%FSS
Pressure hysteresis <sup>(3)</sup>	–	±0.015	±0.030	%FSS
Repeatability	–	±0.010	±0.030	%FSS
Temp. effect on span <sup>(4)</sup>	–	±0.5	±1.0	%FSS
Temp. effect on offset <sup>(4)</sup>	–	±0.5	±1.0	%FSS
Thermal hysteresis (0 °C to 82 °C [32 °F to 180 °F])	–	±0.1	±0.3	%FSS
Long-term stability of offset and span <sup>(5)</sup>	–	±0.1	±0.3	%FSS
Response time <sup>(6)</sup>	–	0.1	–	ms
Common mode voltage (voltage version “K”) <sup>(9)</sup>	0.5	1.3	2.0	Vdc
Input impedance (current version “L”)	1.5	4.5	8.0	kΩ
Input impedance (voltage version “K”)	8.0	25	50	kΩ
Output resistance	3.0	4.5	6.0	kΩ

## 19U VACUUM GAGE UNCOMPENSATED SERIES PERFORMANCE CHARACTERISTICS <sup>(1)</sup>

Characteristic	Minimum	Typical	Maximum	Unit
Zero pressure offset	-7.5	1.0	7.5	mV/V
Full-scale span <sup>(2)</sup> (0 psig to positive full-scale)	35	40	60	mV/V
Pressure non-linearity <sup>(3)</sup>	–	±0.1	±0.25	%FSS
Pressure hysteresis <sup>(3)</sup>	–	±0.015	±0.030	%FSS
Repeatability	–	±0.010	±0.030	%FSS
Temp. coefficient of resistance <sup>(10)</sup> (0 °C to 82 °C [32 °F to 180 °F])	2700	3420	4500	ppm/°C
Temp. coefficient of offset <sup>(10)</sup> (0 °C to 82 °C [32 °F to 180 °F])	–	30	–	µV/V/°C
Temp. coefficient of span <sup>(10)</sup> (0 °C to 82 °C [32 °F to 180 °F])	360	720	1260	ppm/°C
Thermal hysteresis (0 °C to 82 °C [32 °F to 180 °F])	–	±0.1	±0.3	%FSS
Long-term stability of offset and span <sup>(5)</sup>	–	±0.1	±0.3	%FSS
Response time <sup>(6)</sup>	–	±0.1	–	ms
Input resistance	4.00	4.75	6.0	kΩ
Output resistance	4.00	4.75	6.0	kΩ

# Pressure Sensors

## Low-Cost, Stainless Steel, Isolated Sensors

## 19 mm Series

### NOTES

1. Reference conditions (unless otherwise noted):  $T_A = 25\text{ }^\circ\text{C}$  [77  $^\circ\text{F}$ ]; 19C Supply  $V_S = 10\text{ Vdc} \pm 0.01\text{ Vdc}$  or  $I_S = 1.5\text{ mA} \pm 0.0015\text{ mA}$ ; 19U Supply  $V_S = 5\text{ Vdc} \pm 0.01\text{ Vdc}$  or  $I = 1.0\text{ mA} \pm 0.0015\text{ mA}$
2. Full-scale span (FSS) is the algebraic difference between the output voltage at full-scale pressure and the output at zero pressure. FSS is ratiometric to supply voltage.
3. Pressure non-linearity is based on best-fit straight line from zero to the full-scale pressure. Pressure hysteresis is the maximum output difference at any point within the operation pressure range for increasing and decreasing pressure.
4. Maximum error band of the offset voltage or span over the compensated temperature range, relative to the 25  $^\circ\text{C}$  [77  $^\circ\text{F}$ ] reading.
5. Long-term stability over a six-month period.
6. Response time for a 0 psi to FSS pressure step change, 10 % to 90 % rise time.
9. Common mode voltage as measured from output to ground. For higher levels of common mode voltage, contact factory.
10. The error band resulting from a maximum deviation of a transducer's output parameter (offset, span, or resistance) as temperature is varied 25  $^\circ\text{C}$  [77  $^\circ\text{F}$ ] to any other temperature within the specified range (0  $^\circ\text{C}$  to 82  $^\circ\text{C}$  [32  $^\circ\text{F}$  to 180  $^\circ\text{F}$ ]). This parameter is not 100 % tested and is guaranteed by process design and tested on a sample basis only. Temperature coefficient of span is evaluated using a constant current source.

### PHYSICAL DIMENSIONS, for reference only, mm [in]

#### Package 1 (see note): Cell Package

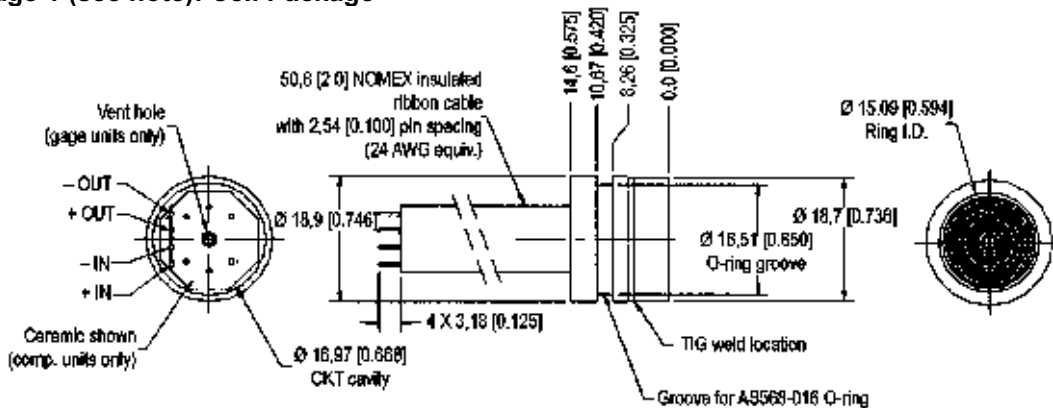

**Note:** Non-concentricity effects at the diaphragm weld area may cause runout of up to  $\pm 0.006$  in between the upper and lower portions of the sensor body. (It is recommended to use a counter bore to mate with this device to allow for this non-concentricity).

#### Package 2: Flush Mount Package

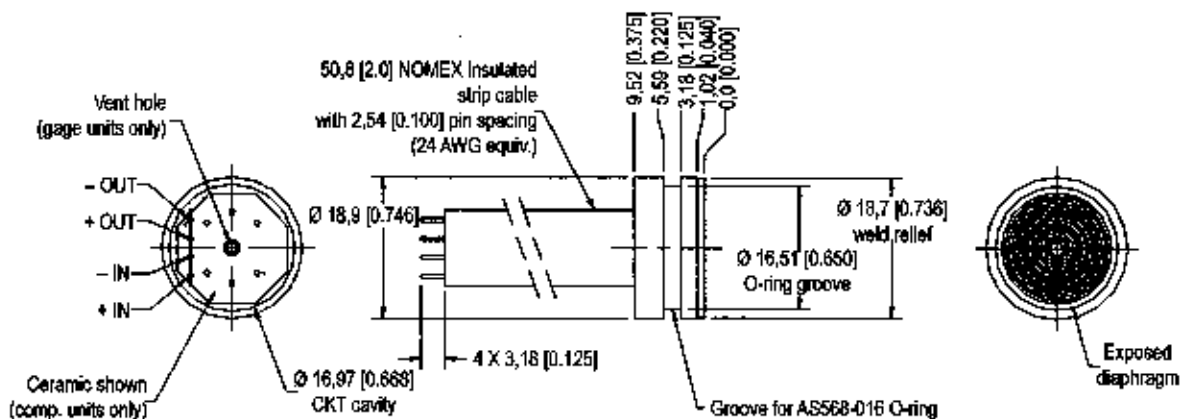

# Pressure Sensors

Low-Cost, Stainless Steel, Isolated Sensors

*19 mm Series*

## Package 3: Flush Mount with Flange

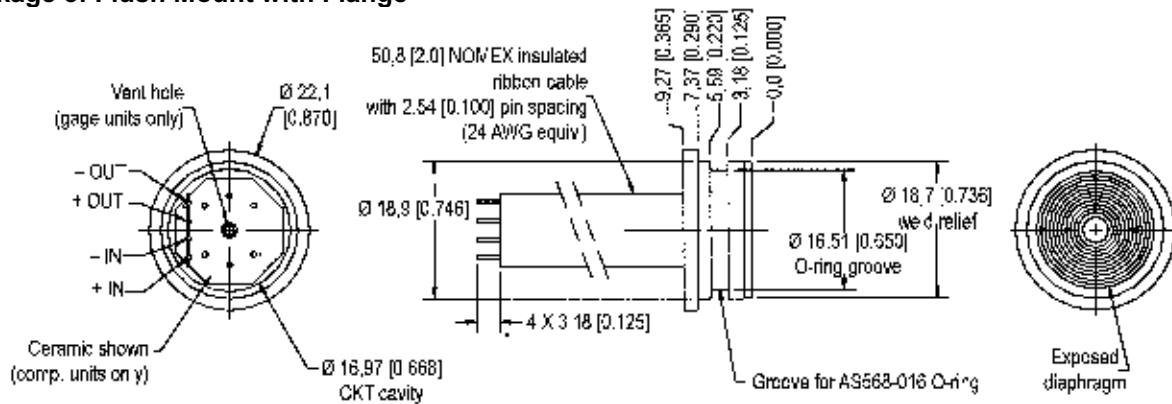

## Package 4: Male 1/8-27 NPT

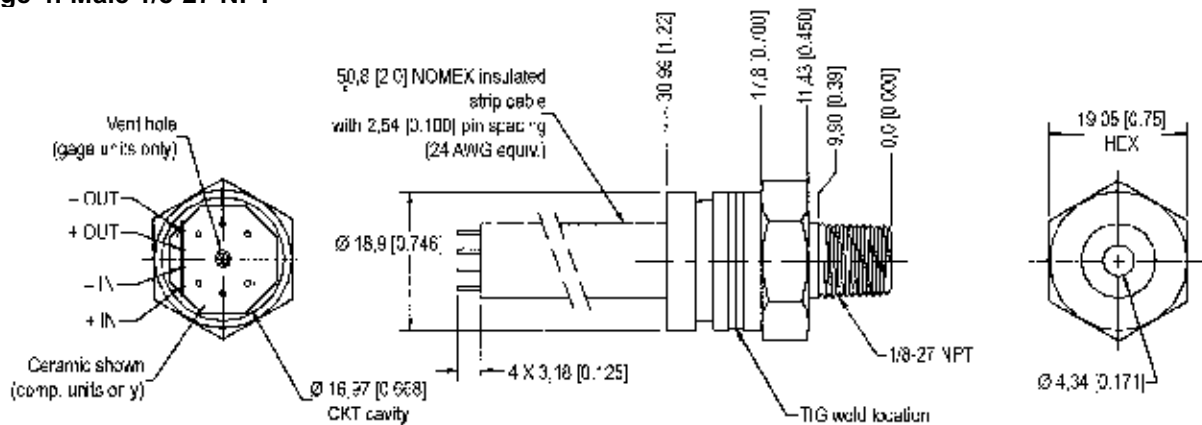

## Package 5: Male 1/4-18 NPT

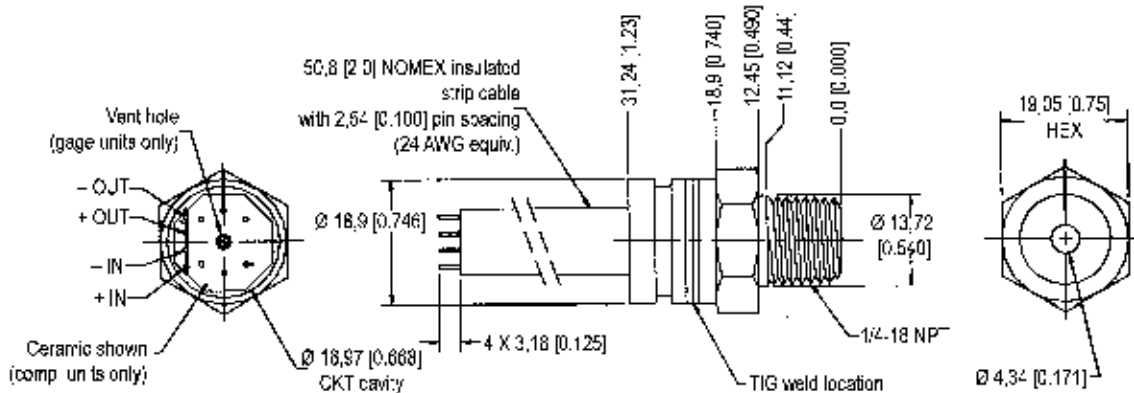

# Pressure Sensors

Low-Cost, Stainless Steel, Isolated Sensors

*19 mm Series*

## Package 6: Male 7/16 UNF

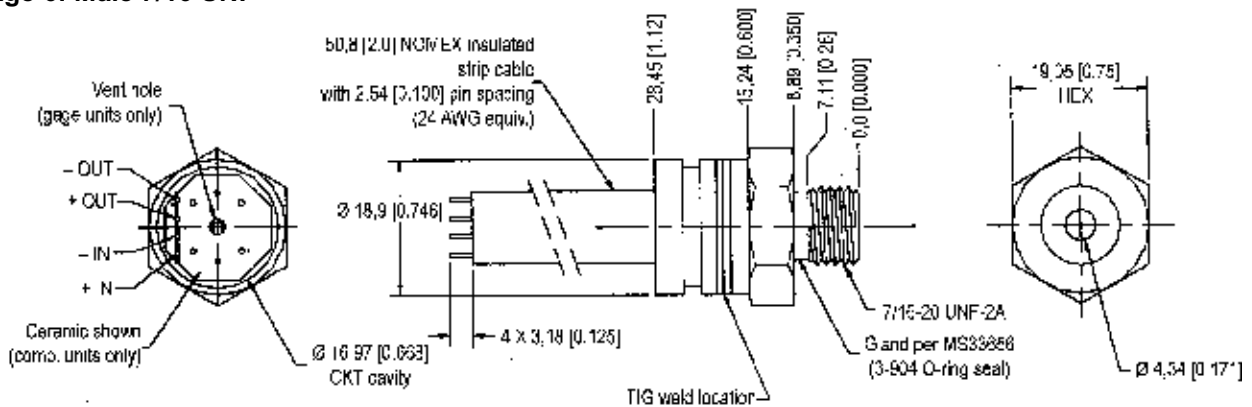

## Package 7: Male 1/4 BSPP

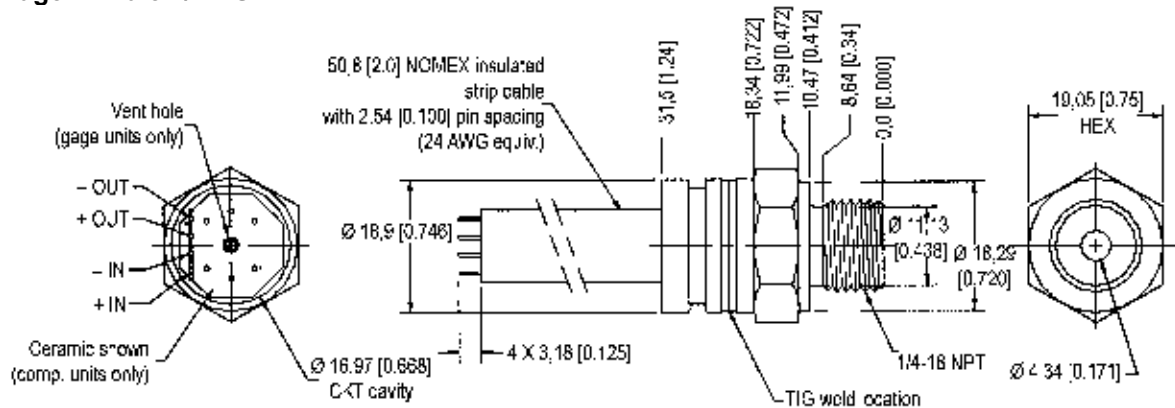

## Package 8: Euro Ring (See note)

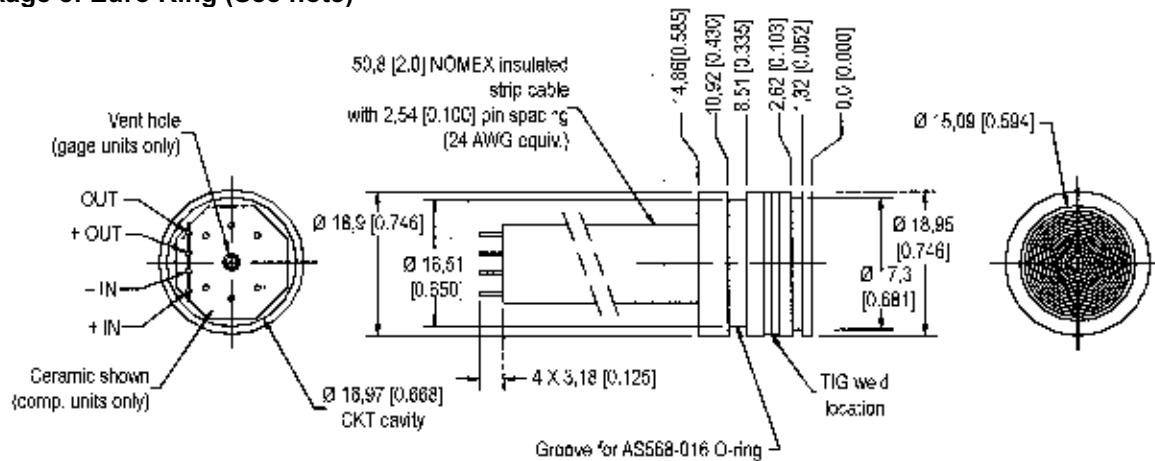

**Note:** Non-concentricity effects at the diaphragm weld area may cause runout of up to  $\pm 0.006$  in between the upper and lower portions of the sensor body. (It is recommended to use a counter bore to mate with this device to allow for this non-concentricity).

# Pressure Sensors

Low-Cost, Stainless Steel, Isolated Sensors

19 mm Series

## Package 9: VCR Gland (Female nut)

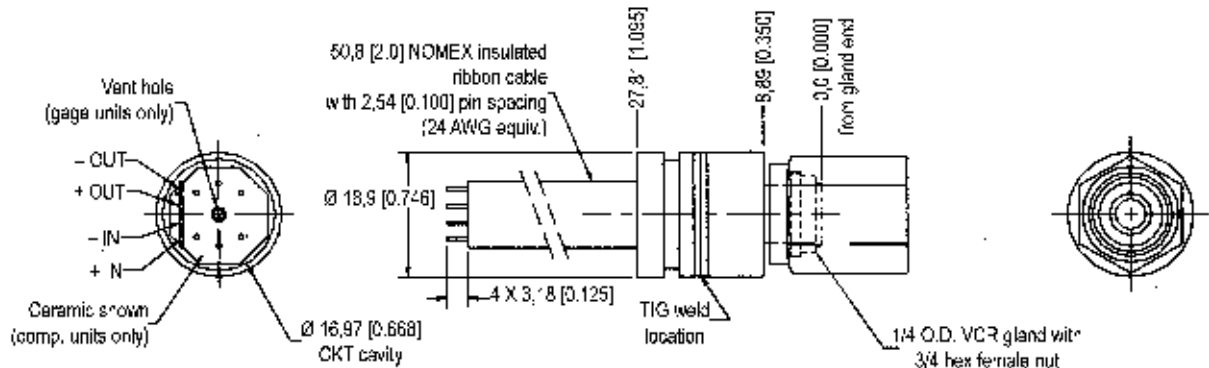

## ORDERING INFORMATION

### 19C Series

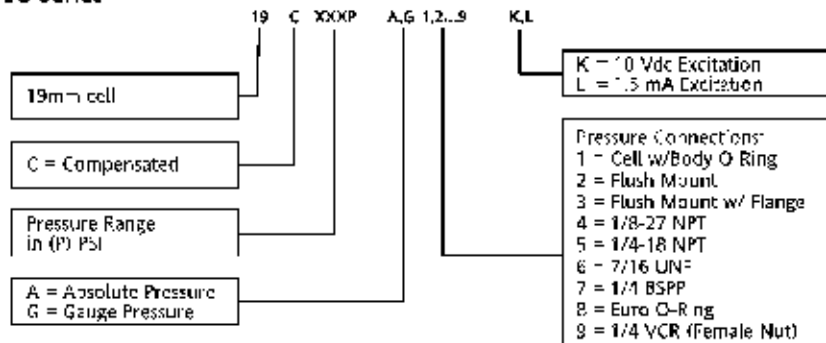

For example:  
Part #19C100PA4K =  
19 mm Cell,  
Compensated, 100 psi,  
Absolute, 1/8NPT Port  
with 10 Vdc excitation.

### 19U Series

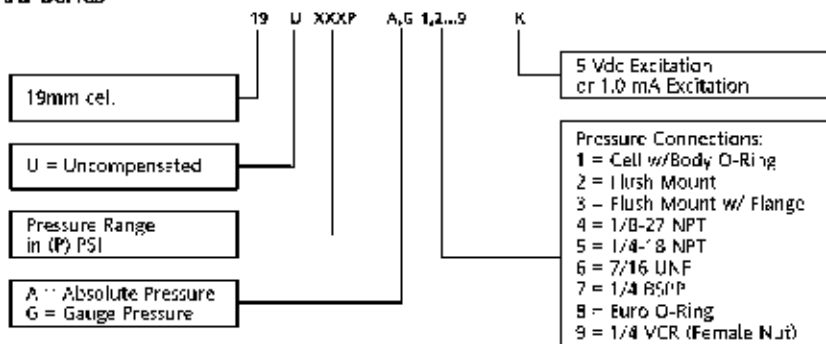

For example:  
Part #19U100PA4K =  
19 mm Cell,  
Uncompensated, 100  
psi, Absolute, 1/8NPT  
Port with 5 Vdc  
excitation.

### 19 Vacuum Gauge Series

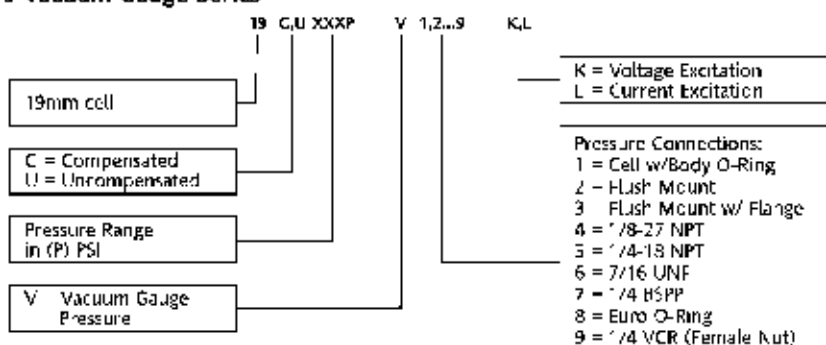

For example: Part #19C100PV4K = 19 mm Cell, Comp., 100 psi, Vacuum Gauge, 1/8NPT Port with 10 Vdc excitation

For example: Part #19U100PV4K = 19 mm Cell, Uncompensated, 100 psi, Absolute, 1/8NPT Port with 5 Vdc excitation.

# Pressure Sensors

Low-Cost, Stainless Steel, Isolated Sensors

*19 mm Series*

## WARRANTY/REMEDY

Honeywell warrants goods of its manufacture as being free of defective materials and faulty workmanship. Contact your local sales office for warranty information. If warranted goods are returned to Honeywell during the period of coverage, Honeywell will repair or replace without charge those items it finds defective. **The foregoing is Buyer's sole remedy and is in lieu of all other warranties, expressed or implied, including those of merchantability and fitness for a particular purpose.**

Specifications may change without notice. The information we supply is believed to be accurate and reliable as of this printing. However, we assume no responsibility for its use.

While we provide application assistance personally, through our literature and the Honeywell web site, it is up to the customer to determine the suitability of the product in the application.

For application assistance, current specifications, or name of the nearest Authorized Distributor, contact a nearby sales office. Or call:

1-800-537-6945 USA/Canada

1-815-235-6847 International

## FAX

1-815-235-6545 USA

## INTERNET

[www.honeywell.com/sensing](http://www.honeywell.com/sensing)

[info.sc@honeywell.com](mailto:info.sc@honeywell.com)

---

# Honeywell

Sensing and Control

[www.honeywell.com/sensing](http://www.honeywell.com/sensing)

Honeywell

11 West Spring Street

Freeport, Illinois 61032