

Monnit Commercial

Wireless AC Current Meter (AA)



Technical Overview

General Description

The wireless AC Current Meter measures the RMS current of an alternating current (AC) system using a current transformer (CT) that wraps around the “hot” wire of a two wire (hot, common, ground(optional)) power system. The sensor reports Minimum RMS current, maximum RMS current, average RMS current, and amp hours to the iMonnit system. The iMonnit system is capable of generating watt hour or kilowatt hour readings as well.

Features

- Measures amp hours, max RMS current, min RMS current, and average RMS current.
- Two different current transducers available:
 - Low Current: 0-20 Amp
 - High Current: 0-150 Amp
- Capable of generating Watt Hour or Kilowatt Hour readings using iMonnit.
- Data logging for accumulated amp hour readings.
- Can notify based on current levels or changes in current levels.
- Simple and safe installation of current/power measurement hardware, no rewiring required.
- Free iMonnit basic online wireless sensor monitoring and notification system to configure sensors, view data and set alerts via SMS text and email.

Principle of Operation

To measure current, clip the CT around only a single wire of the AC system (clipping around a hot and neutral wire at the same time will result in 0 current readings). After the sensor powers on and connects to the gateway it will begin taking measurements based on the averaging interval (5 seconds default). It will report data to iMonnit every heartbeat or if the current goes outside of the aware thresholds set in iMonnit. The sensor reports amp hours, max RMS current, min RMS current, and average RMS current. iMonnit can also generate watt hour or kilowatt hour readings if a default RMS voltage is set in iMonnit.

Applications

- Current Monitoring
- Amperage Monitoring
- Current Usage
- Amp Hour Meter

Monnit Sensor Core Specifications

- Power: Two replaceable 1.5 V AA batteries (Option for line power with battery backup)
- Communication: RF 900, 920, 868 and 433 MHz
- Dimensions: 4.375" x 2.470" x 1.111"
- Antenna: 4" wire antenna
- Operating Temperature: -40° to 85°C (-40° to 185°F)
- Device Range: 250 - 300 ft. non-line-of-sight*
- Battery Life: At 1 hour heartbeat setting, standard AA batteries will last up to 4 years.**

- * Actual range may vary depending on environment.
- ** Battery life is determined by sensor reporting frequency and other variables. Other power options are also available.

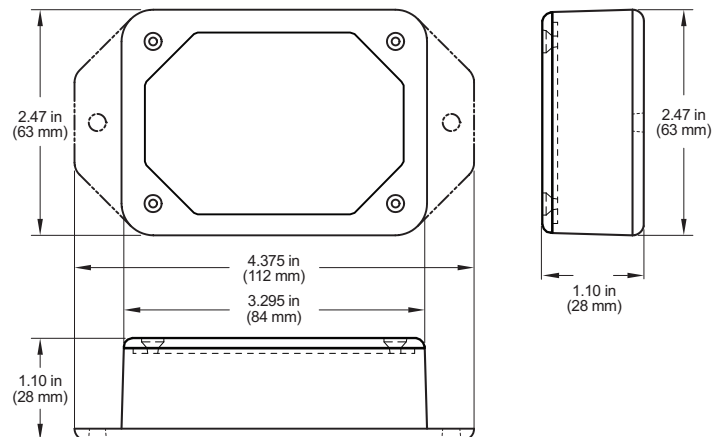

Power Options

The standard version of this sensor is powered by two replaceable 1.5V AA sized batteries (included with purchase). This sensor is also available in a line power version with battery backup, allowing it to be powered by a standard 3.0 - 3.6V power supply and use the internal batteries if there is a power interruption.

Power options must be selected at time of purchase as the internal hardware of the sensor must be changed to support the selected power requirements.

Technical Specifications	
Supply Voltage	2.0 - 3.6 VDC (3.0 - 3.6 VDC Using Power Supply) *
Current Consumption	0.7 μ A (sleep mode) 2 mA (radio idle/off mode) 2 mA (measurement mode) 25 mA (radio RX mode) 35 mA (radio TX mode)
Operating Temperature Range (Board Circuitry and Batteries)	-18°C to 55°C (0°F to 130°F) using alkaline -40°C to 85°C (-40°F to 185°F) using lithium **
Optimal Battery Temperature Range (AA)	+10°C to +50°C (+50°F to +122°F)
Certifications	 900 MHz product; FCC ID: ZTL- RFSC1 and IC: 9794A-RFSC1. 920 MHz product; ARIB STD-T108 R210-103733. 868 and 433 MHz product tested and found to comply with: CISPR 22:2008-09 / EN 55022:2010 - Class B and ETSI EN 300 220-2 V2.4.1 (2012-05).
0-20 Amp Model	
Absolute Max CT Current	50 Amps RMS (Arms)
Maximum Accurate CT Current	20 Arms
Frequency Range	50 – 100 Hz
Accuracy	+/- 2% @ 2 to 20 Arms, +/- .07 Arms @ < 2 Arms***
Calibrated Accuracy with Appropriate Offset	+/- 1% @ 2 to 20 Arms, +/- .035 Arms @ < 2 Arms***
Offset Limits	-1.27 to + 1.27 Arms (default set to +.1 Arms) ****
Measurement Resolution	~.01 Arms
Current Transducer Dimensions	40 mm x 25 mm x 26 mm (10 mm inner diameter)
0-150 Amp Model	
Absolute Max CT Current	200 Amps RMS (Arms)
Maximum Accurate CT Current	150 Arms
Frequency Range	50 – 100 Hz
Accuracy	+/- 2% @ 2 to 150 Arms, +/- .4 Arms @ < 15 Arms***
Calibrated Accuracy with Appropriate Offset	+/- 1% @ 2 to 150 Arms, +/- .2 Arms @ < 2 Arms***
Offset Limits	-1.27 to + 1.27 Arms (default set to +.3 Arms) ****
Measurement Resolution	~.1 Arms
Current Transducer Dimensions	67 mm x 49 mm x 42 mm (24 mm inner diameter)

* Hardware cannot withstand negative voltage. Please take care when connecting a power device.

** At temperatures above 100°C, it is possible for the board circuitry to lose programmed memory.

*** CTs are inherently less accurate at or below 10% of max range. For best calibration results calibrate at a current between 30% and 90% of max accurate range.

**** Offset is used to overcome a diode voltage drop inherent to the hardware. To accurately account for this drop a default offset is used. To best identify the optimal value of this offset make a series of measurements at .2 to 2 Arms and find the current (Arms) difference between your measurement standard and the Monnit sensor.

Use this product within the specified temperature range. Higher temperature may cause deterioration of the characteristics or the material quality of this product.

