

Monnit

Wireless Vehicle Sensors (AA)



Technical Overview

General Description

The Wireless vehicle sensors can be used in a host of applications where detecting or counting vehicles is needed. Two different vehicle sensors are available.

Features

- Detects presence of vehicles up to 8 feet away.
- Can detect and count stationary or moving vehicles.
- Free iMonnit basic online wireless sensor monitoring and notification system to configure sensors, view data and set alerts via SMS text and email.

Principles of Operation

Vehicle Detection - Detects the presence or absence of a parked or stationary vehicle.

Vehicle Counter - Detects and counts vehicles in motion as they pass by.

Power Options

The standard version of this sensor is powered by two replaceable 1.5 V AA sized batteries (included with purchase).

This sensor is also available with a line power option. The line powered version of this sensor has a barrel power connector allowing it to be powered by a standard 3.0 - 3.6 V power supply. The line powered version also uses two standard 1.5 V AA batteries as backup for uninterrupted operation in the event of line power outage.

Power options must be selected at time of purchase, as the internal hardware of the sensor must be changed to support the selected power requirements.

Monnit Sensor Core Specifications

- Power: Two replaceable 1.5 V AA batteries (Option for line power with battery backup)
- Communication: RF 900, 920, 868 and 433 MHz
- Dimensions: 4.375" x 2.470" x 1.111"
- Antenna: 4" wire antenna
- Operating Temperature: -40° to 85°C (-40° to 185°F)
Device Range: 250 - 300 ft. non-line-of-sight*
- Battery Life: At 1 hour heartbeat setting, standard AA batteries will last up to 4 years.**

* Actual range may vary depending on environment.
** Battery life is determined by sensor reporting frequency and other variables. Other power options are also available.

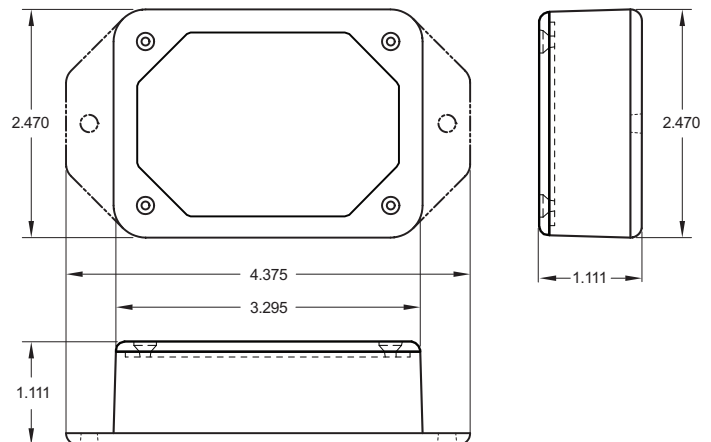

Example Applications

- Parking Garages
- Traffic Monitoring
- Automotive Services
- Fleet Management
- And many more...

The Leader in Low Cost Wireless Sensors

Technical Specifications	
Supply Voltage	2.0 - 3.6 VDC (3.0 - 3.6 VDC Using Power Supply) *
Vehicle Sensing Distance	Up to 8 feet
Field Range (Full scale (FS) - total applied field)	-8 to +8 gauss
Mag Dynamic Range (3-bit gain control)	±1 to ±8
Resolution (VDD=3.0V, GN=2)	5 milli-gauss typ.
Linearity (±2.0 gauss input range)	0.1 ±% FS max
Hysteresis (±2.0 gauss input range)	±25 ppm typ.
Cross-Axis Sensitivity (Cross field = 0.5 gauss)	±0.2% FS / gauss
Output Rate (Continuous Measurement Mode)	0.75 to 75 Hz
Output Rate (Single Measurement Mode)	160 Hz max
Measurement Period	6 msec typ.
Gain Tolerance	±5%
Gain Tolerance (Ambient, unbiased)	-40 to +125°C
Operating Temperature Range (Board Circuitry and Batteries)	-18°C to 55°C (0°F to 130°F) using alkaline -40°C to 85°C (-40°F to 185°F) using lithium **
Optimal Battery Temperature Range (AA)	+10°C to +50°C (+50°F to +122°F)
Certifications	 900 MHz product; FCC ID: ZTL- RFSC1 and IC: 9794A-RFSC1. 920 MHz product; ARIB STD-T108 R210-103733. 868 and 433 MHz product tested and found to comply with: CISPR 22:2008-09 / EN 55022:2010 - Class B and ETSI EN 300 220-2 V2.4.1 (2012-05).

* At temperatures above 100°C, it is possible for the board circuitry to lose programmed memory.

Caution/Notice:

This product is designed for application in an ordinary environment (normal room temperature, humidity and atmospheric pressure). Do not use this sensor under the following conditions as these factors can deteriorate the product characteristics and cause failures and burn-out.

- Corrosive gas or deoxidizing gas - chlorine gas, hydrogen sulfide gas, ammonia gas, sulfuric acid gas, nitric oxides gas, etc.).
- Volatile or flammable gas.
- Dusty conditions.
- Under low or high pressure.
- Wet or excessively humid locations.
- Places with salt water, oils chemical liquids or organic solvents.
- Where there are excessively strong vibrations.
- Other places where similar hazardous conditions exist.

Use this product within the specified temperature range. Higher temperature may cause deterioration of the characteristics or the material quality of this product.

