

Monnit

Wireless Resistance Sensor (AA)



Technical Overview

General Description

The Monnit Wireless Resistance Sensor reports the resistance across a load. It can be connected to any kind of passive (no voltage) variable resistance device.

Features

- Measures up to 145 KOhms.
- Accurate to $\pm 1.5\%$ (FS) with user calibration.
- Interfaces with any variable resistance device.
- Free iMonnit basic online wireless sensor monitoring and notification system to configure sensors, view data and set alerts via SMS text and email.

Principle of Operation

The Monnit Wireless Resistance Sensor reads the resistance across any resistive device and reports back the measured resistance. The resistance sensor leads are meant to connect to passive devices only, connecting the sensor leads to any voltage or power source may damage the sensor. It is programmed to sleep for a user-given time interval (heartbeat) and then wake up, convert the analog data, mathematically compute the resistance, and transmit the data to the gateway, where it is then logged into the cloud service. The user can configure defined thresholds and have the system alert on threshold breaches.

Power Options

The standard version of this sensor is powered by two replaceable 1.5 V AA sized batteries (included with purchase).

This sensor is also available with a line power option. The line powered version of this sensor has a barrel power connector allowing it to be powered by a standard 3.0 - 3.6 V power supply. The line powered version also uses two standard 1.5 V AA batteries as backup for uninterrupted operation in the event of line power outage.

Power options must be selected at time of purchase, as the internal hardware of the sensor must be changed to support the selected power requirements.

Monnit Sensor Core Specifications

- Power: Two replaceable 1.5 V AA batteries (Option for line power with battery backup)
- Communication: RF 900, 920, 868 and 433 MHz
- Dimensions: 4.375" x 2.470" x 1.111"
- Antenna: 4" wire antenna
- Operating Temperature: -40° to 85°C (-40° to 185°F)
Device Range: 250 - 300 ft. non-line-of-sight*
- Battery Life: At 1 hour heartbeat setting, standard AA batteries will last up to 4 years.**

* Actual range may vary depending on environment.

** Battery life is determined by sensor reporting frequency and other variables. Other power options are also available.

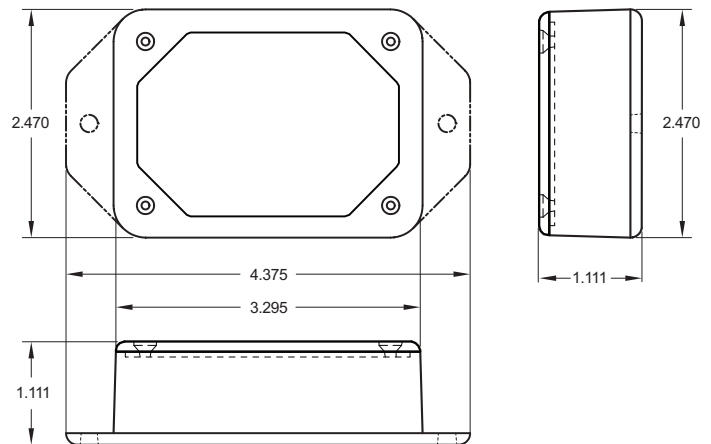

Example Applications

- Resistance Monitoring
- Battery Monitoring
- Transducer Interfacing

The Leader in Low Cost Wireless Sensors

Technical Specifications	
Supply Voltage	2.0 - 3.6 VDC (3.0 - 3.6 VDC Using Power Supply) *
Current Consumption	0.7 μ A (sleep mode) 2 mA (radio idle/off mode) 2 mA (measurement mode) 25 mA (radio RX mode) 35 mA (radio TX mode)
Operating Temperature Range (Board Circuitry and Batteries)	-18°C to 55°C (0°F to 130°F) using alkaline -40°C to 85°C (-40°F to 185°F) using lithium **
Optimal Battery Temperature Range (AA)	+10°C to +50°C (+50°F to +122°F)
Resistive Range (in Ohms)	0 – 145000***
Specific Resistive Ranges (in Ohms)	0 – 530, 530 – 3500, 3500 – 27200, 27200 - 145000
Resolution (in Ohms)	2047 Unique Values Per Specific Range (11 bit): ~.25, ~1.71, ~13.3, ~70.8.
Accuracy	+/- 3% FS of Specific Range
User Calibrated Accuracy	+/- 1.5% FS of Specific Range****
Lead Wire Length	1 ft. (12 in.)
Certifications	 900 MHz product; FCC ID: ZTL- RFSC1 and IC: 9794A- RFSC1. 920 MHz product; ARIB STD-T108 R210- 103733. 868 and 433 MHz product tested and found to comply with: CISPR 22:2008-09 / EN 55022:2010 - Class B and ETSI EN 300 220-2 V2.4.1 (2012-05).

* Hardware cannot withstand negative voltage. Please take care when connecting a power device.

** At temperatures above 100°C, it is possible for the board circuitry to lose programmed memory.

*** The sensor is capable of measuring above 145000 Ohms but may not meet the specified accuracy above this value.

**** For a valid calibration, the resistance under measurement must be maintained in circuit for 1 data transmission before calibration and 1 data transmission after calibration. Calibration is only applied to the specific resistive range, for best results calibrate at a resistance between 10% and 90% of the specific range. In general, calibrating between the 50% and 90% points of the specific range will yield better calibration results for the entire range.

Caution/Notice:

This product is designed for application in an ordinary environment (normal room temperature, humidity and atmospheric pressure). Do not use this sensor under the following conditions as these factors can deteriorate the product characteristics and cause failures and burn-out.; corrosive gas or deoxidizing gas - chlorine gas, hydrogen sulfide gas, ammonia gas, sulfuric acid gas, nitric oxides gas, etc.), volatile or flammable gas, dusty conditions, under low or high pressure, wet or excessively humid locations, places with salt water, oils chemical liquids or organic solvents, where there are excessively strong vibrations, other places where similar hazardous conditions exist.

Use this product within the specified temperature range. Higher temperature may cause deterioration of the characteristics or the material quality of this product.

MONNIT[®]