

Monnit

Wireless DC Voltage Detection Sensor



Technical Overview

General Description

The Monnit DC Voltage Detector detects the presence or absence of electricity. It is intended for use on battery or other DC sources, up to 50 Volts. Not intended for use with AC Voltages. It is perfect for batteries, adapters, solar equipment, vehicles or machinery, and any other electrical appliance monitoring. The sensor triggers on voltage presence to voltage Absence and vice versa. The data is displayed as "Voltage Detected" or "No Voltage".

Features

- Detects presence or absence of voltage.
- Voltage presence detected above ~.47 volts.
- Voltage absence detected below ~.47 volts.
- Detects voltages up to 50 volts.
- Reverse voltage protection, up to 50 Volts.
- Free iMonnit basic online wireless sensor monitoring and notification system to configure sensors, view data, and set alerts via SMS text and email.

Principle of Operation:

The Monnit DC Voltage Detector detects the presence or absence of voltage. The sensor triggers on voltage presence to voltage absence and vice versa. The data is displayed as "Voltage Detected" or "No Voltage". If no change is observed within the heartbeat interval, the state is continuously reported on the heartbeat interval. Transitions and heartbeat data is logged into a cloud service. The user can set the system to send an alert on either state, or on the transition of states.

Power Options

Sensors are powered by a replaceable 3.0 V coin cell battery. Optional AA battery powered sensors are available. The AA version of these sensors are larger in size (3" [L] x 2.1" [W] x 1.2" [H]) and include two long-life AA batteries.

It is recommended that unless you are using the AA battery solution, you set heartbeat to no faster than one hour to preserve battery life.

Monnit Sensor Core Specifications

- Power: Replaceable 3.0 V coin cell battery
- Communication: RF 900, 920, 868 and 433 MHz
- Dimensions: 1.775" x 1.040" x 0.785"
- Antenna: 4" wire antenna
- Operating Temperature: -7° to 60°C (20° to 140°F)
- Device Range: 250 - 300 ft. non-line-of-sight*
- Battery Life: At 1 hour heartbeat setting, coin cell battery will last ~ 1-2 years.**

* Actual range may vary depending on environment.

** Battery life is determined by sensor reporting frequency and other variables.

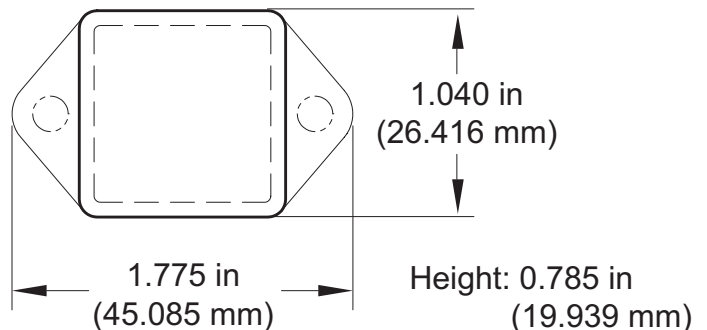

Example Interfacing

- Battery Power
- Relays/Switches
- Appliances
- Adapters
- Solar
- Power Supplies
- Sump Pumps
- And many more...

The Leader in Low Cost Wireless Sensors

Technical Specifications	
Supply Voltage	2.0 - 3.6 VDC
Current Consumption	0.7 μ A (sleep mode) 2 mA (radio idle/off mode) 2 mA (measurement mode) 25 mA (radio RX mode) 35 mA (radio TX mode)
Operating Temperature Range (Board Circuitry and Coin Cell)	-7°C to +60°C (20°F to +140°F)*
Optimal Battery Temperature Range (Coin Cell)	+10°C to +50°C (+50°F to +122°F)
Maximum Rated Input Voltage	50.0 Volts
Minimum Rated Input Voltage	-50.0 Volts
Voltage Detection Threshold	Present above ~.47 Volt, Absent below ~.47 Volt
Trigger	Transmits data upon state change
Open Circuit Reading	Voltage Absent
Leaded Wire Specification	2 Wires, 1 ft. (12 in.), Red (+), Black (-), 18 AWG (Custom lengths available upon request)
Certifications	 900 MHz product; FCC ID: ZTL- RFSC1 and IC: 9794A-RFSC1. 920 MHz product; ARIB STD-T108 R210-103733. 868 and 433 MHz product tested and found to comply with: CISPR 22:2008-09 / EN 55022:2010 - Class B and ETSI EN 300 220-2 V2.4.1 (2012-05).

* At temperatures above 100°C, it is possible for the board circuitry to lose programmed memory.

Proper Installation:

If the sensor is not connected to the power source properly, it will appear that the sensor is broken. Please follow this wiring diagram to ensure proper performance and detection.

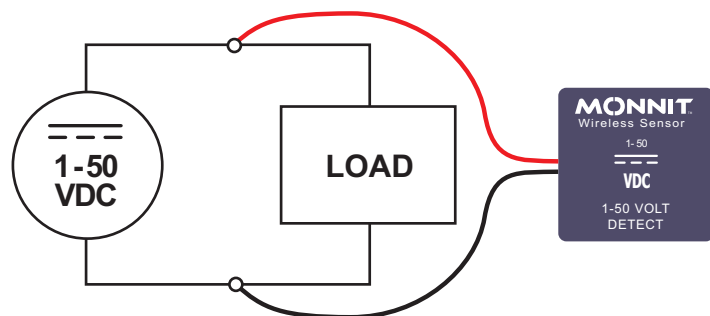

Caution/Notice:

This product is designed for application in an ordinary environment (normal room temperature, humidity and atmospheric pressure). Do not use this sensor under the following conditions as these factors can deteriorate the product characteristics and cause failures and burn-out.; corrosive gas or deoxidizing gas - chlorine gas, hydrogen sulfide gas, ammonia gas, sulfuric acid gas, nitric oxides gas, etc.), volatile or flammable gas, dusty conditions, under low or high pressure, wet or excessively humid locations, places with salt water, oils chemical liquids or organic solvents, where there are excessively strong vibrations, other places where similar hazardous conditions exist.

Use this product within the specified temperature range. Higher temperature may cause deterioration of the characteristics or the material quality of this product.

MONNIT®