

4112 Dew Point and Temperature Transmitter

Specification

Overview

The Honeywell 4112 Dew Point and Temperature Transmitter represents a technological breakthrough in moisture measurement. Absolute moisture in processes at high pressure and temperatures up to 100°C/212°F higher than existing equipment is now a reality opening the door to better product quality, improved thermal efficiency, and longer process equipment life.

Description

The Honeywell 4112 Dew Point Transmitter is a direct intrusion, FM-approved dew point and dry bulb temperature transmitter for industrial environments. It was designed to meet the moisture-measuring requirements of a wide variety of industrial processes. Customers can now measure moisture where they have been previously unable to do so because of temperature limits, contaminants, and harsh environments.

Features

- Easy-to-read LCD Display
- FM approval for hazardous environments
- Patented contamination-resistant sensor
- In-situ use
- Explosion-proof housing
- AC or dc operation
- High-resolution analog to digital conversion
- Rugged, no maintenance sensor
- Dual 4-20 mA output signals
- Optional cooler for in-situ use in high temperature environments

- Optional probe for use in high pressure environments
- NIST traceable

Unique features include

- Dew Point and Dry Bulb Temperature Displays —A dual display that continuously provides both dew point and dry bulb temperatures is standard on every 4112 unit. Display options are also available to read humidity ratio, relative humidity, or wet bulb temperature. The display can be turned 180° to accommodate mounting orientation. Display resolution is 0.1°C. The sample rate is less than 0.33 seconds.
- FM Approval- Approved for use by FM **for explosion-proof areas**. The approval covers areas classified under Class 1, Division 1, Groups B, C and D and dust ignition-proof for Class II, Division 1, Groups E, F and G.

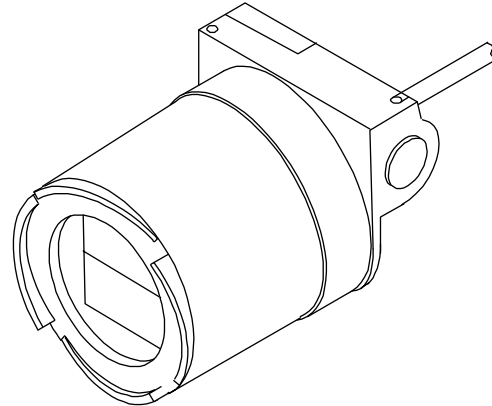

Benefits

- Lowers energy costs
- Eliminates need for sampling systems
- Reduces calibration maintenance

Applications

- Industrial drying
- Food processing
- Power generation monitoring and control
- Heat treatment
- Instrument air
- Pharmaceutical
- Chemical manufacturing
- Pulp and paper
- Natural Gas Pipeline (110 option)

The 4112 provides

Superior Performance

The high-performance sensing element combines moisture sensing and platinum RTD temperature sensing at the tip of an advanced probe design. Dew point accuracy does not require any sampling system or sample conditioning. It does not even require that the sensor temperature be the same as the bulk gas temperature. Consult Honeywell for available probe accessories that can provide accurate process control capability even under normally condensing conditions or extreme temperature conditions.

- *High temperature operation up to 185°C*—The 4112 is designed to operate continuously at temperatures up to 185°C (365°F) and will survive brief excursions to 204°C (400°F). The optional cooler allows safe operation of the sensor at process temperatures up to 540°C (1000°F). Note: Maximum operating temperature for Option 110 Probe is 150°C (300°F).
- *More than 100°C dew point depression*—Chilled sensor systems literally “depress” the temperature of a sensor until dew or frost forms. “Depression” on the 4112, however, is not dependent on the cooling capabilities of the sensor; therefore, DP depressions greater than 100°C below dry bulb are finally a reality. See the minimum dew point capability graph for more detail.
- *Saves energy*—Many high temperature processes such as drying or steaming are energy intensive and often inefficient because of imprecise control. The 4112 can be used not only to save energy costs, but also to improve existing process and process control technologies.
- *Advanced probe design*—Advanced probe design virtually eliminates temperature effects and parasitic capacitance. New advanced materials and sensor assembly techniques enhance performance in high temperature conditions.
- *High resolution A/D conversion*—A high resolution 12-bit A/D converter is used to convert the analog sensor signals for the digital processor. This provides 16 times the resolution of 8-bit converters. This adds to the overall accuracy of the dew point system, making accuracy of better than 1°C achievable. The 4-20 mA signal as well as both digital displays are updated more than three times per second.
- *Unequaled environmental tolerance*—The 4112 has superior tolerance to contaminants. Common solvents, dirt, oil, and other pollutants do not affect the stability or accuracy of the sensor. The polymer coating on the sensor has excellent environmental tolerance. A porous platinum layer over the sensing polymer layer eliminates the sensing external contamination and a final polymer topcoat protects the sensor. The sensor connections are potted in a custom molded plug to exclude contamination. Response time may be slowed by heavy contaminant layers, but the accuracy is unaffected.
- *Dry bulb temperature accuracy*—The 4112 uses Honeywell’s own precision ULTRA-7™ thin film platinum RTD for dry bulb temperature measurement. System calibration ensures very high temperature measurement accuracy. The 4-20 mA current signal for dry bulb temperature is a continuous analog output.

Ease of Use

- *Easy maintenance*—The 4112 reduces the long hours of routine cleaning and recalibrations required to maintain the accuracy of other types of commonly used dew point sensors. If the sensor does get coated with process contaminants, simply wipe it clean with isopropyl alcohol or mild detergent. Recalibration after cleaning is not required.
- *External non-interactive on-site calibration*—The analog dry bulb transmitter output is externally calibrated by using fully independent zero and span screwdriver adjustments. Dew point adjustment can be digitally stepped up or down with an external screwdriver actuator. These sealed adjustments maintain the environmental and explosion-proof integrity of the housing during on-site adjustment. Circuits are further protected from condensation by a water-resistant compartment.

- *Works in-situ*—The sensor for the 4112 is designed for direct immersion into the process. This unique sensor eliminates the need for filtered environments, cumbersome “sampling” of the process or disruptive “self-cleaning.”
- *One-point field calibration*—Calibration is simple—one pot, one point, one adjustment. Only the temperature zero setting and the dew point span setting need adjusting for routine field calibration.
- *110 Vac or 24 Vdc 2-wire operation*—Unlike other dew point systems, the 4112 can be wired for either 110 Vac or 2-wire 11-45 Vdc.

Specifications

Performance	
Transmitter Resolution	Better than 0.3 times accuracy or 1°C
Display Resolution	0.1°C
Accuracy	See accuracy graphs
Input Voltage Effect	0.002%/V max. (negligible) from 11 to 45 Vdc
Serviceability	
Periodic Maintenance	Verify calibration periodically. Wash sensor as needed.
Adjustments	Vernier, noninteracting, multiturn potentiometers for zero and span control of dry bulb temperature. Momentary rotary action switches for dew point calibration. Adjustments are on the outside of the transmitter housing under a swing-away plate.
Sensor Break Indication	Dry bulb sensor: upscale both output signals Dew point sensor: downscale on dew point signal only
Over-temperature Indication	Dew point output at 100°C when dry bulb >192°C
Sensor Cleaning	Wash with isopropyl alcohol or detergent solution. Rinse with deionized water. Camel hair (organic) brush can be used during cleaning when required.

Specifications

Installation		
	Standard Probe	High Pressure Probe (Option 110)
Transmitter Housing	NEMA 4X, IP65 cast low-copper aluminum fully anodized with aliphatic urethane finish. Weight approximately 2.0 kg (4.4 lb).	
Sensor Housing	Stainless steel probe, fluted shield, porous stainless steel filters	Stainless steel probe, porous stainless steel filter
Mounting	Can be mounted on pipe or wall	Pipe Mount
Sensor Operating Environment	-50°C to 185°C (-58°F to 365°F)	-50°C to 150°C (-58°F to 300°F)
Transmitter Operating Environment	-40°C to 80°C (-40°F to 176°F)	
Storage Environment	-55°C to 85°C (-67°F to 185°F)	
Power Requirements	115 Vac \pm 10%, 60 Hz with R_{Lmax} 500 ohm or 11 Vdc + ($R_{load} \times 0.02$ A) min. to 45 Vdc max. for dual 2-wire operation	
Intrinsic Safety Entity Parameters	V max. = 30 volts; I max. = 360 mA; C_i = 0.1 μ F; L_i = 0 mH	
Signal Connection	Screw Terminals	
Sensor Mounting	1/2" NPT	3/4" NPT
Pressure	0 to 350 psi	0 to 2000 psi

Dew Point Accuracy Graphs

To use the dew point accuracy graphs, first determine the operating temperature and dew point for the application. For example, if a D1 unit is measuring a dry bulb temperature of 150C and a dew point of 50C, then locate the 150C point on the X-axis of the D1 graph. Follow a line straight left to the Y-axis. That point represents accuracy of about ±4.5C. And the D3 unit, for example has dew point accuracy of about ±2C when dry bulb is 20C and frost point is 30C.

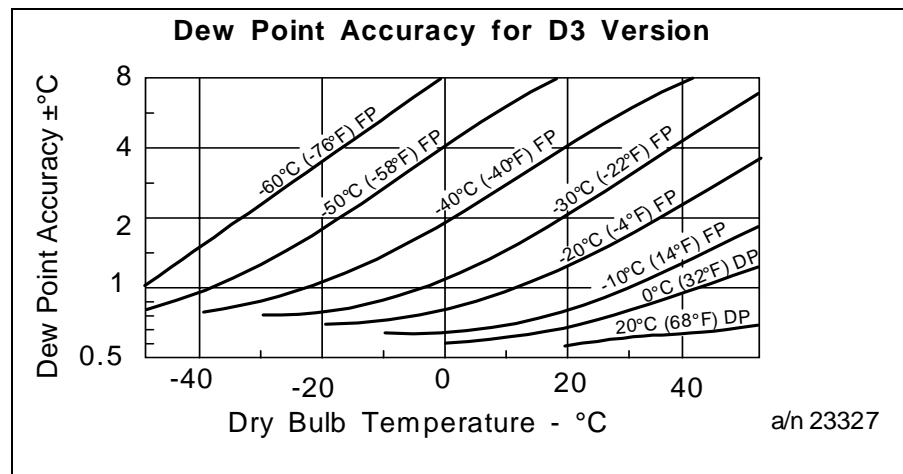
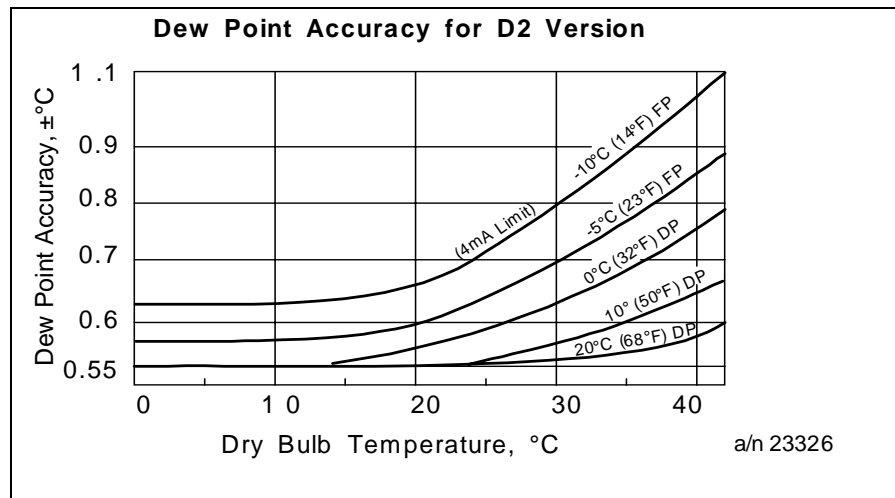
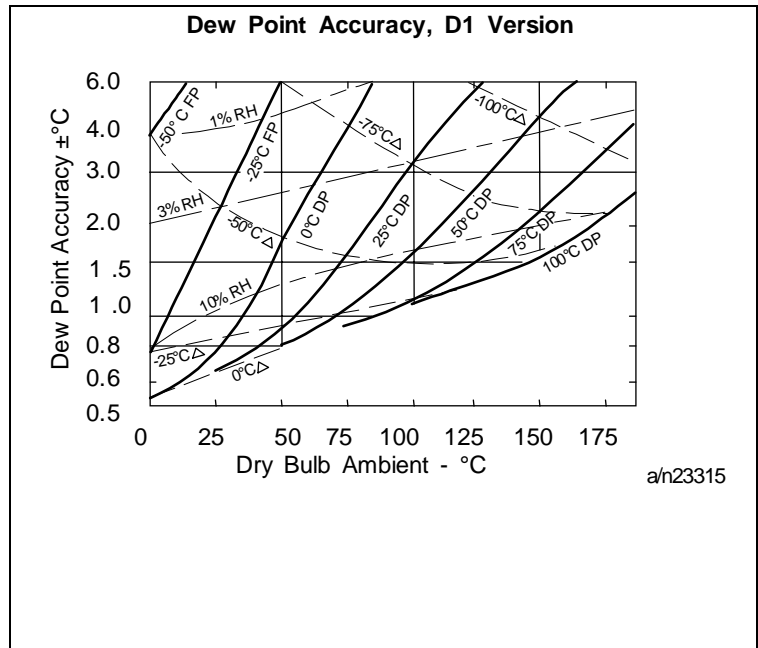

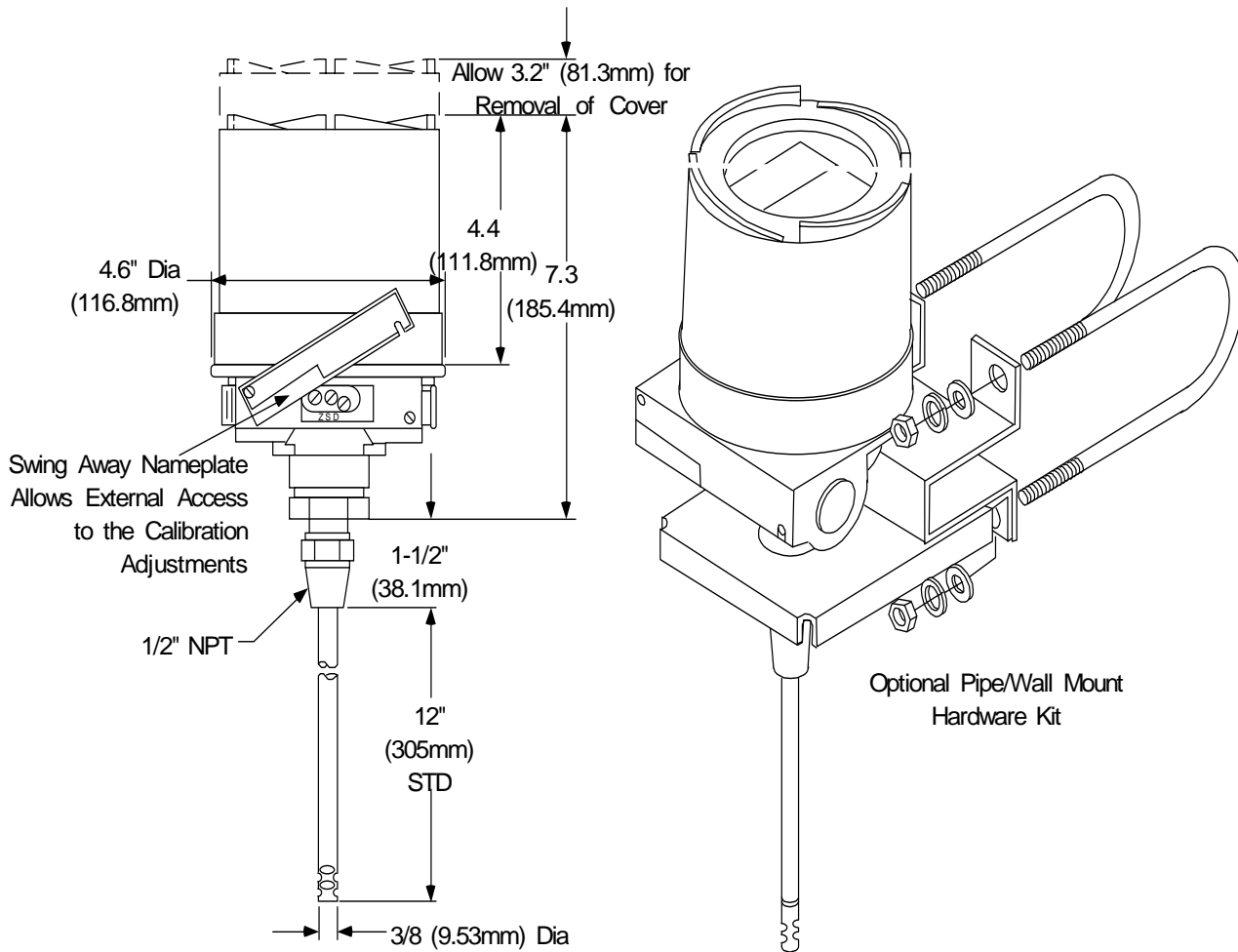

**4112 Dew Point and Temperature Transmitter Mounting
and Dimension Drawing**

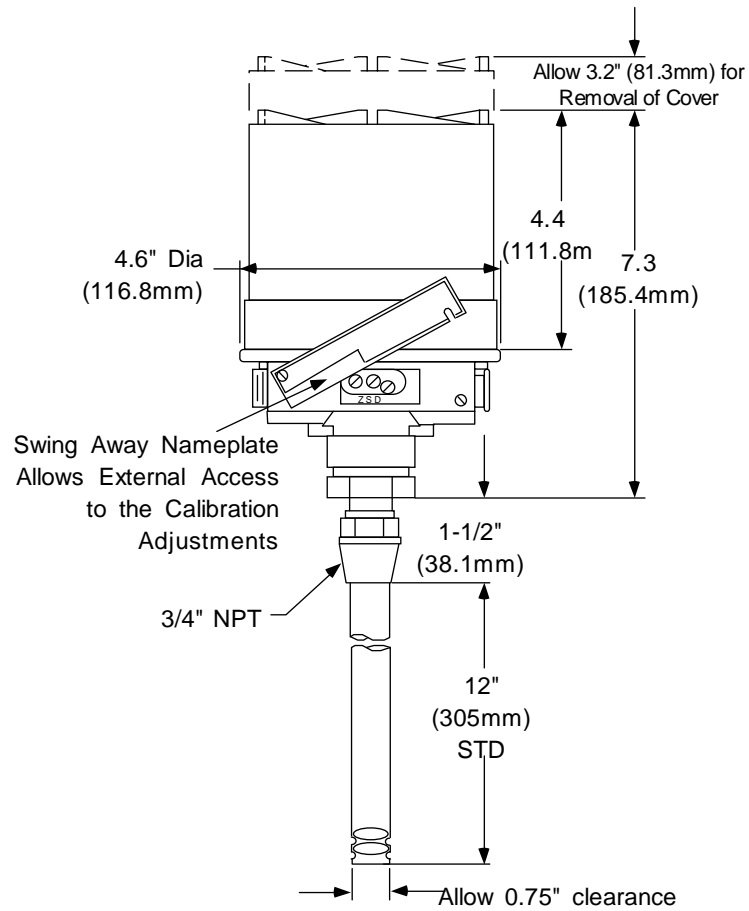

**4112 (Option 110) Dew Point and Temperature Transmitter
Mounting and Dimension Drawing**

Distributor :

Industrial Automation and Control

Honeywell Inc.

In the U.S.A.: Honeywell Industrial Automation and Control, 16404 North Black Canyon HWY., Phoenix, AZ 85023, (800) 343-0228

In Europe: Honeywell S.A., 80084 Amiens Cedex 2, (33) 22.54.56.56

Honeywell Control System Ltd., Honeywell House, Bracknell, UK-RG 12 1 EB, (44) 1344 826000

In Japan: Yamatake-Honeywell Co. Ltd., Nagai Int'l Bldg., 2 - 12 - 19 Shibuya-Ku, Tokyo 150 Japan, 81-3-3486-2051

In Asia: Honeywell Asia Pacific Inc., Room 3213-3225, Sun Hung kai Centre, No. 30 Harbor Road, Wanchai, Hong Kong, (852) 829-8298

In the Mediterranean: Africa and Middle East Region, Honeywell SpA, Via Vittor Pisani 13, 20124 Milano, Italy (39-2) 67731

Honeywell Pacific Division: Honeywell Pty Ltd., 5 Thomas Holt Drive, North Ryde Sydney, NSW Australia 2113, (61-2) 353 7000

In Canada: The Honeywell Centre, 155 Gordon Baker Road, Ontario M2H 3N7, 1-800-461-0013

In Latin America: Honeywell Inc., 14505 Commerce Way, Suite 500, Miami Lakes, Florida 33016-1556, (305) 364-2300