



Wireless Range Extender

General Description

Monnit Wireless Range Extenders allow you to extend the coverage area (range) of your wireless sensor network by relaying data between your wireless sensors and the wireless gateway.

Principle of Operation

On power up, the range extender will locate a wireless gateway that has the “best” signal available. The device then auto-configures itself to communicate and link with this gateway. After linking with the parent gateway, the range extender then establishes itself as a sub-network with it’s own dedicated channel to the gateway, relieving congestion from multi-sensor networks.

As data is generated in the range extender’s sub-network, it will intelligently store and forward this information to its parent gateway. This conserves battery power on the wireless sensors, increases network reliability, and intelligently manages network traffic to avoid cluttering.

When a Monnit wireless sensor is locating a network, it will search for the “best” wireless signal. If the best signal is a range extender, the sensor will auto-configure itself to link with the range extender (no user intervention required). A range extender will permit a wireless sensor to link if one of the following conditions is met:

- The range extender already knows the wireless sensor and permits linking.
- The range extender confirms the wireless sensor’s permissions from its parent gateway.

Wireless Range Extender Features

- Extends the coverage area of your wireless sensor network
- Supports up to 99 wireless devices
- Supports up to 6 messages / minute
- Built in memory can queue up to 30,000 messages for delivery to the gateway
- AC powered, so no batteries needed

Applications

- Facilities / Building Operations
- Property Management
- Warehouse Monitoring
- Hotel / Motel Monitoring
- Food Chain Monitoring
- Restaurants / Food Services
- Convenience Stores
- Asset Management
- Agriculture and Greenhouses

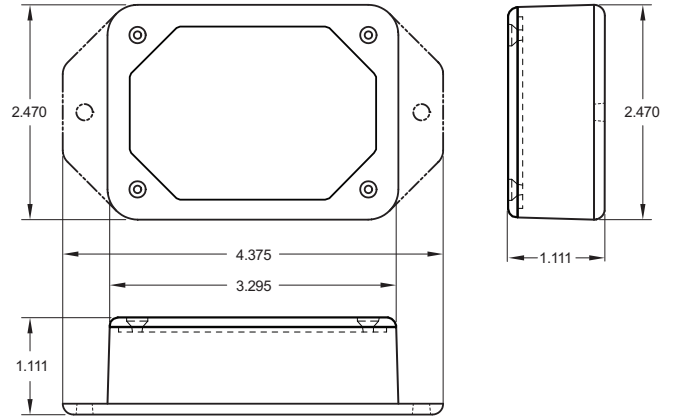

Wireless Range Extender - Technical Specifications

Power

Input Power	5.0 - 6.5 VDC
Operating Current	<0.05 Amps

Wireless Operation

Maximum Wireless Devices Per Gateway	Up to 100 Total Wireless Devices Per Gateway
Maximum Devices	Up to 99 Monnit Wireless Devices Per Range Extender (sensors, control, local alert and other range extenders)
Message Storage / Memory	30,000 Messages
Recommended Network Communications	Up to 6 Messages Per Minute
Range Extender Communication Delay	Up to 30 Seconds (At number of recommended network communications)

Mechanical

LEDs	Single LED H/W Status / Activity <ul style="list-style-type: none"> • Flashing Red/Green (device is looking for an APN to join) • Solid Red (no network found) • Solid Green (device has joined a network) • Flashing Green (sensor data is intercepted and relayed)
Enclosure	ABS Plastic UL94V-0 Flame Rating
Dimensions	3.09 in. x 2.085 in. x 1.417 in. (78.486 mm x 52.959 mm x 35.992 mm)
Weight	5.5 ounces

Environmental

Operating Temperature	-40°C to +85°C (-40°F to +185°F)
-----------------------	----------------------------------

Certifications

	900 MHz product; FCC ID: ZTL- RFSC1 and IC: 9794A-RFSC1. 920 MHz product; ARIB STD-T108 R210-103733. 868 and 433 MHz product tested and found to comply with: CISPR 22:2008-09 / EN 55022:2010 - Class B and ETSI EN 300 220-2 V2.4.1 (2012-05).
--	--

Notes:

Commercial Grade Products

Monnit commercial grade products are designed for applications in ordinary environments (normal room temperature, humidity and atmospheric pressure). Do not use these products under the following conditions as these factors can deteriorate the product characteristics and cause failures and burn-out.

- Corrosive gas or deoxidizing gas - chlorine gas, hydrogen sulfide gas, ammonia gas, sulfuric acid gas, nitric oxides gas, etc.)
- Volatile or flammable gas
- Dusty conditions
- Under low or high pressure
- Wet or excessively humid locations
- Places with salt water, oils chemical liquids or organic solvents
- Where there are excessively strong vibrations
- Other places where similar hazardous conditions exist

Use these products within the specified temperature range. Higher temperature may cause deterioration of the characteristics or the material quality.

