

Model 1604-1607

Standard Rotating Shaft Torque Sensor



DESCRIPTION

A line of rotary transformer torque sensors often ideal for test installations running long-term durability testing. Non-contact nature of the signal transfer virtually eliminates the need for maintenance. High overload protection with high signal output helps prevent potential damage to the sensor. Carrier frequency

excitation provides increased signal/noise immunity. Capacity range from 50 in-lb to 100000 in-lb for shaft mounting configurations.

FEATURES

- 50 in-lb to 100000 in-lb capacity
- 0.1 % non-linearity and hysteresis
- Speed sensor and/or foot mount (optional)
- High overload protection with high signal output (sensitivity)
- Minimal maintenance due to bearings only contact
- Carrier frequency excitation provides increased signal/noise immunity

Model 1604-1607

PERFORMANCE SPECIFICATIONS

Characteristic	Measure
Torque range	50 lb-in to 100000 lb-in
Non-linearity	±0.1 % of rated output
Hysteresis	±0.1 % of rated output
Repeatability	±0.05 % of rated output
Output @ rated capacity	2 mV/V (nominal)

ENVIRONMENTAL SPECIFICATIONS

Characteristic	Measure
Temperature, operating	-29 °C to 93 °C [-20 °F to 200 °F]
Temperature, compensated	21 °C to 77 °C [70 °F to 170 °F]
Temperature effect, zero	±0.002 % of rated output/°F
Temperature effect, output	±0.002 % of reading/°F

ELECTRICAL SPECIFICATIONS

Characteristic	Measure
Excitation	3.28 kHz optimum @ 10 Vac max. RMS
Insulation resistance	> 5000 mOhm @ 50 Vdc
Bridge resistance	350 ohm (nominal)
Number of bridges	1
Zero balance	±1.0 % of rated output

TYPICAL SYSTEM DIAGRAM

Mating Connectors & Cables

- 064-LW13621 Mating connector
- 064-LW13656 Mating connector, speed pickup
- 064-LW25469 Mating connector, zero velocity speed pickup
- 7200-28-XX* Mating connector & 6 conductor cable (unamplified unit with sense leads but not shunt cal)
- 7200-106-XX* Mating connector & 6 conductor cable (for connection to instrument 7541)
- 7204-00-XX* Speed sensor cable, pigtail leads at instrument
- 7204-16-XX* Speed sensor cable to instrument 7541
- 7220-47-XX* Zero velocity speed sensor cable, pigtail leads at instrument
- 7220-119-XX* Zero velocity speed sensor cable to instrument 7541

* XX represents length in feet 100ft maximum

** XX represents length in feet 20ft maximum

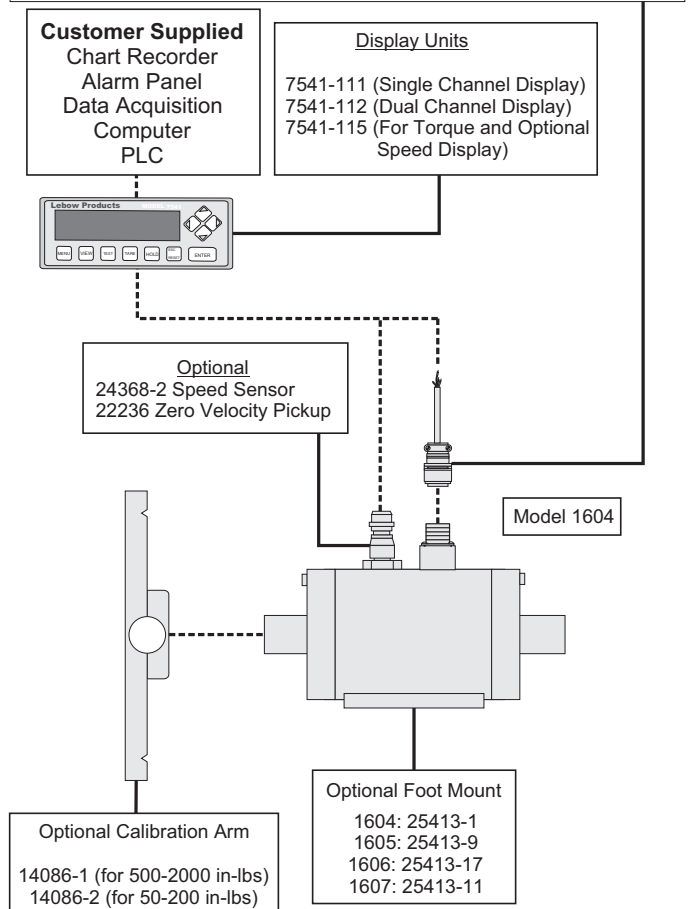

Standard Rotating Shaft Torque Sensor

MECHANICAL SPECIFICATIONS

Model	Capacity lb-in	Capacity N-m	Max speed RPM	Protected for overloads to lb-in	Torsional stiffness lb-in/rad	Rotating inertia lb-in sec ²	Weight kg [lb]
1604-50	50	5	10000	150	5000	2.59 x 10 ⁻³	8,20 [18]
1604-100	100	10	10000	300	13500	2.59 x 10 ⁻³	8,20 [18]
1604-200	200	20	10000	600	33000	2.59 x 10 ⁻³	8,20 [18]
1604-500	500	55	10000	1500	85000	2.59 x 10 ⁻³	8,20 [18]
1604-1K	1000	115	10000	3000	150000	2.59 x 10 ⁻³	8,20 [18]
1604-2K	2000	225	10000	3000	225000	2.59 x 10 ⁻³	8,20 [18]
1605-2K	2000	225	10000	6000	700000	8.41 x 10 ⁻³	12,70 [28]
1605-5K	5000	565	10000	15000	950000	8.41 x 10 ⁻³	12,70 [28]
1605-10K	10000	1130	10000	20000	1000000	8.41 x 10 ⁻³	12,70 [28]
1606-20K	20000	2250	6700	60000	4080000	3.62 x 10 ⁻²	18,20 [40]
1606-30K	30000	3390	6700	60000	4080000	3.62 x 10 ⁻²	18,20 [40]
1607-50K	50000	5650	6000	150000	11800000	0.15	34,10 [75]
1607-100K	100000	11300	6000	150000	19950000	0.47	34,10 [75]

MOUNTING DIMENSIONS

Model	C cm [in]	L cm [in]	N cm [in]	P cm [in]	U cm [in]	K cm [in]	A cm [in]	B cm [in]	D cm [in]	E cm [in]	F cm [in]	H cm [in]
1604	25,40 [10]	15,24 [6]	5,32 [2]	10,16 [4]	2,54 [1.00]*	0,64 [0.25 sq]*	12,07 [4.75]	8,89 [3.50]	5,40 [2.13]	5,08 [2]	3,49 [1.38]	0,71 [0.28]
1605	32,39 [12.75]	18,42 [7.25]	6,99 [2.75]	11,99 [4.75]	3,81 [1.50]	0,95 [0.38 sq.]	16,51 [6.25]	10,16 [4]	6,35 [2.50]	6,67 [2.63]	3,81 [1.50]	1,03 [0.41]
1606	40,01 [15.75]	20,96 [8.25]	9,53 [3.75]	13,97 [5.50]	5,72 [2.25]	1,27 [0.50 sq.]	18,42 [7]	13,34 [5.25]	7,62 [3]	7,62 [3]	5,08 [2]	1,35 [0.53]
1607	48,26 [19]	22,23 [8.75]	13,02 [5.13]	16,51 [6.50]	7,62 [3.00]	1,91 [0.75 sq.]	24,59 [8.50]	13,97 [5.50]	8,89 [3.50]	8,89 [3.50]	5,08 [2]	1,35 [0.53]

* 50, 100, 200 lb-in units: K=3/16 in sq., U=3/4 in

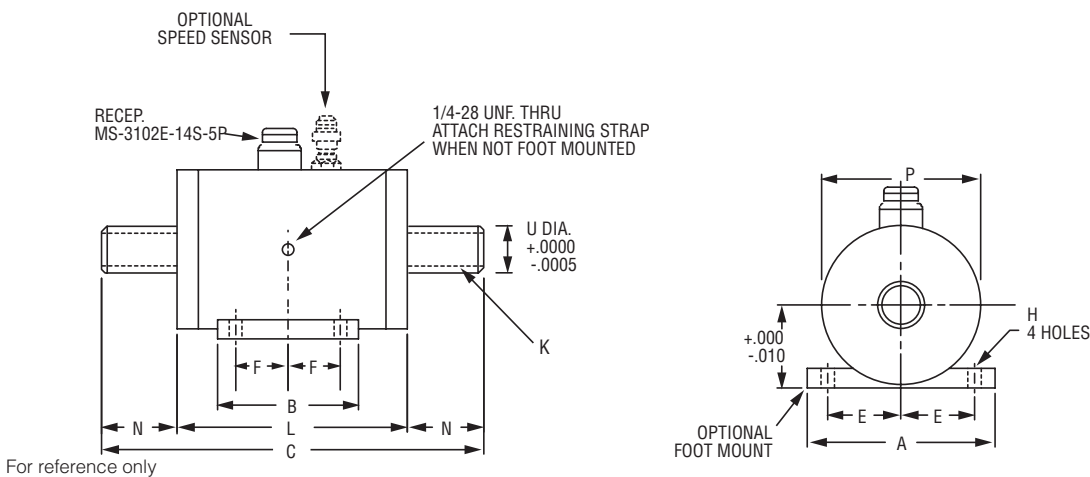

Model 1604-1607

Standard Rotating Shaft Torque Sensor

Warranty. Honeywell warrants goods of its manufacture as being free of defective materials and faulty workmanship. Honeywell's standard product warranty applies unless agreed to otherwise by Honeywell in writing; please refer to your order acknowledgement or consult your local sales office for specific warranty details. If warranted goods are returned to Honeywell during the period of coverage, Honeywell will repair or replace, at its option, without charge those items it finds defective. **The foregoing is buyer's sole remedy and is in lieu of all warranties, expressed or implied, including those of merchantability and fitness for a particular purpose. In no event shall Honeywell be liable for consequential, special, or indirect damages.**

While we provide application assistance personally, through our literature and the Honeywell web site, it is up to the customer to determine the suitability of the product in the application.

WARNING

PERSONAL INJURY

- DO NOT USE these products as safety or emergency stop devices or in any other application where failure of the product could result in personal injury.

Failure to comply with these instructions could result in death or serious injury.

WARNING

MISUSE OF DOCUMENTATION

- The information presented in this datasheet is for reference only. DO NOT USE this document as product installation information.
- Complete installation, operation and maintenance information is provided in the instructions supplied with each product.

Failure to comply with these instructions could result in death or serious injury.

Find out more

Honeywell serves its customers through a worldwide network of sales offices, representatives and distributors. For application assistance, current specifications, pricing or name of the nearest Authorized Distributor, contact your local sales office. To learn more about Honeywell's test and measurement products, call **+1-614-850-5000**, visit **<http://measurementsensors.honeywell.com>**, or e-mail inquiries to **info.tm@honeywell.com**

Sensing and Control
Honeywell
1985 Douglas Drive North
Golden Valley, MN 55422 USA
honeywell.com

Honeywell