

Model 1815

Enhanced Accuracy Rotary Torque Sensor



DESCRIPTION

A line of enhanced accuracy rotary transformer torque sensors often ideal for test installations running long-term durability testing. Non-contact nature of the signal transfer virtually eliminates the need for maintenance. High overload protection with high signal output helps prevent potential damage to the sensor.

Carrier frequency excitation provides increased signal/noise immunity. Extended speed range allows shaft rotation up to 25000 RPM. Capacity range from 50 in-lb to 10000 in-lb for shaft mounting configurations.

FEATURES

- 50 in-lb to 10000 in-lb capacity
- 0.05 % non-linearity and hysteresis
- Spline drive/flange mount
- Extended speed range, up to 25000 RPM
- Minimal maintenance due to “bearings only” contact

Safety considerations: It would be unsafe to operate Honeywell torque sensors and load cells beyond static overload or ultimate extraneous load limits as defined in the glossary of terms or, when applicable, higher than maximum speed. When in doubt, consult factory. Honeywell is not responsible for any property damage or personal injury which may result because of the misapplication of the transducer.

Model 7927 shunt cal reference box included with each purchase of 1800 Series.

Flange housing mount with pads to match Army-Navy mountings standard. Spline drive.

Model 1815

PERFORMANCE SPECIFICATIONS

Characteristic	Measure
Torque range	50, 100, 200, 500, 1K, 2K, 5K, 10K lb-in
Non-linearity	±0.05 % of rated output
Hysteresis	±0.05 % of rated output
Repeatability	±0.03 % of rated output
Output @ rated capacity	2 mV/V (nominal)

ENVIRONMENTAL SPECIFICATIONS

Characteristic	Measure
Temperature, operating	-29 °C to 93 °C [-20 °F to 200 °F]
Temperature, compensated	21 °C to 77 °C [70 °F to 170 °F]
Temperature effect, zero	±0.002 %/of rated output °F
Temperature effect, output	±0.002 %/of reading °F

ELECTRICAL SPECIFICATIONS

Characteristic	Measure
Excitation	3.28 kHz optimum @ 10 Vac RMS
Insulation resistance	> 5000 mOhm @ 50 Vdc
Bridge resistance	350 ohm (nominal)
Number of bridges	1
Zero balance	±1.0 % of rated output

TYPICAL SYSTEM DIAGRAM

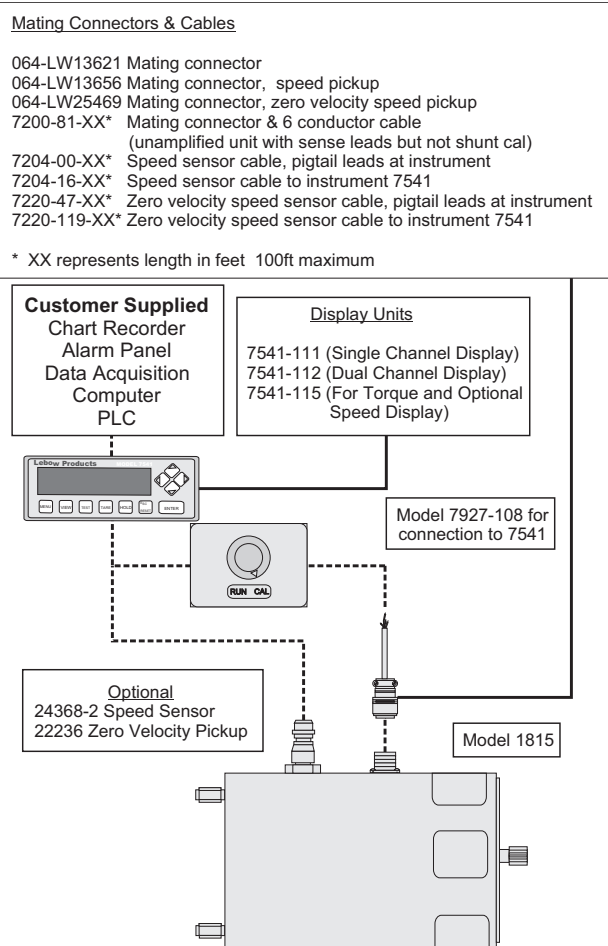

Enhanced Accuracy Rotary Torque Sensor

MECHANICAL SPECIFICATIONS

Model	Capacity lb-in	Capacity N-m	Max speed RPM	Protected for overloads to Nm [lb-in]
1815A-50	50	5	25000	15 [150]
1815A-100	100	10	25000	30 [300]
1815A-200	200	20	25000	60 [600]
1815A-500	500	55	25000	165 [1500]
1815A-1K	1000	115	25000	165 [1500]
1815K-50	50	5	15000	15 [150]
1815K-100	100	10	15000	30 [300]
1815K-200	200	20	15000	60 [600]
1815K-500	500	55	15000	165 [1500]
1815K-1K	1000	115	15000	330 [3000]
1815K-2K	2000	225	15000	675 [6000]
1815K-5K	5000	565	15000	1695 [15000]
1815K-10K	10000	1130	15000	1695 [15000]

INTERNAL AND EXTERNAL SPLINE DATA

Model	Pressure angle	Pitch dia. cm [in]	Pitch	Number of teeth
1815A	30°	2,03 [0.80]	20/40	16
1815K	30°	3,05 [1.20]	20/40	24

MOUNTING DIMENSIONS

Model	A cm [in]	B cm [in]	C cm [in]	D cm [in]	E cm [in]	F cm [in]	G cm [in]	H cm [in]	J cm [in]	K cm [in]	L cm [in]	N cm [in]	P cm [in]
1815A	23,55 [9.27]	2,67 [1.05]	1,60 [0.63]	2,84 [1.12]	20,96 [8.25]	0,36 [0.14]	10,47 [4.12]	10,48 [4.13]	2,62 [1.03]	1,03 [0.41]	12,70 [5.00]	15,24 [6.00]	3/8-24
1815K	25,25 [9.94]	4,29 [1.69]	1,60 [0.63]	4,01 [1.58]	20,96 [8.25]	0,36 [0.14]	10,47 [4.12]	10,48 [4.13]	2,62 [1.03]	1,03 [0.41]	12,70 [5.00]	15,24 [6.00]	3/8-24

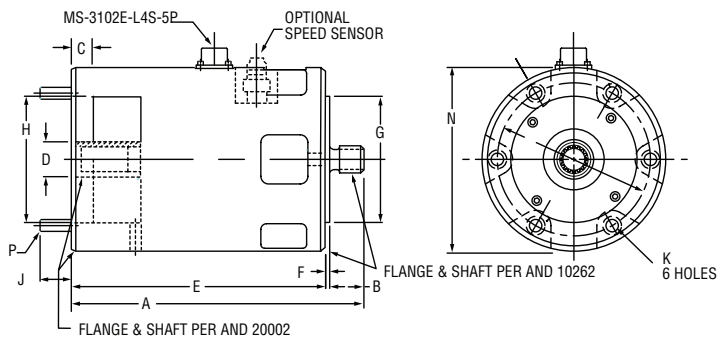

For reference only

Model 1815

Enhanced Accuracy Rotary Torque Sensor

Warranty. Honeywell warrants goods of its manufacture as being free of defective materials and faulty workmanship. Honeywell's standard product warranty applies unless agreed to otherwise by Honeywell in writing; please refer to your order acknowledgement or consult your local sales office for specific warranty details. If warranted goods are returned to Honeywell during the period of coverage, Honeywell will repair or replace, at its option, without charge those items it finds defective. **The foregoing is buyer's sole remedy and is in lieu of all warranties, expressed or implied, including those of merchantability and fitness for a particular purpose. In no event shall Honeywell be liable for consequential, special, or indirect damages.**

While we provide application assistance personally, through our literature and the Honeywell web site, it is up to the customer to determine the suitability of the product in the application.

Specifications may change without notice. The information we supply is believed to be accurate and reliable as of this printing. However, we assume no responsibility for its use.

For more information about Sensing and Control products, visit www.honeywell.com/sensing or call +1-815-235-6847

Email inquiries to info.sc@honeywell.com

 **WARNING**
PERSONAL INJURY

- DO NOT USE these products as safety or emergency stop devices or in any other application where failure of the product could result in personal injury.

Failure to comply with these instructions could result in death or serious injury.

 **WARNING**
MISUSE OF DOCUMENTATION

- The information presented in this catalogue is for reference only. DO NOT USE this document as product installation information.
- Complete installation, operation and maintenance information is provided in the instructions supplied with each product.

Failure to comply with these instructions could result in death or serious injury.

Sensing and Control
Automation and Control Solutions
Honeywell
1985 Douglas Drive North
Golden Valley, MN 55422 USA
+1-815-235-6847
www.honeywell.com/sensing

008781-1-EN IL50 GLO
June 2008
Copyright © 2008 Honeywell International Inc. All rights reserved.

Honeywell