

Low Range Precision Miniature Load Cells

Model 31 Low

008629

Issue 2

Datasheet

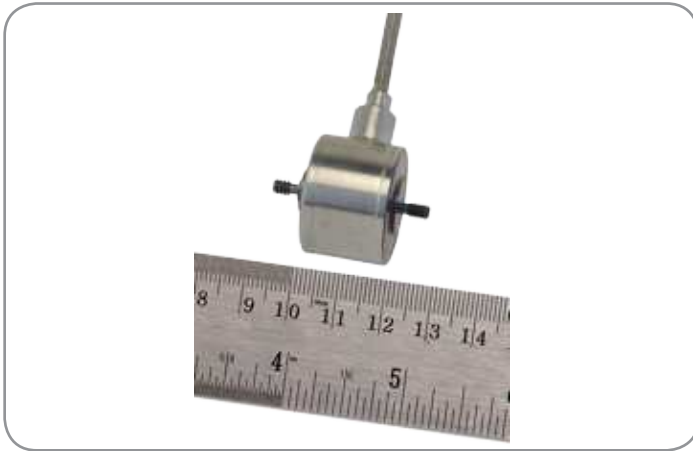

DESCRIPTION

The Model 31 low range, precision, miniature load cells can measure both tension and compression load forces of up to 500 g / 5 N. The Model 31 is a durable miniature load cell, with high accuracy of 0.15 % full scale.

Welded, stainless steel construction is designed to minimize or eliminate the effects of off-axis loads. Each bonded strain gage unit is built of welded 17-4 PH stainless steel with integrated, internal overload stops for enhanced durability.

VALUE TO CUSTOMERS

- Enhanced accuracy of 0.15 %
- Newton and gram force ranges available

FEATURES

- 0,5 N to 5 N / 50 g to 500 g
- mV/V output
- Stainless steel
- Miniature design
- Double diaphragm construction
- Male thread attachments

POTENTIAL APPLICATIONS

- Cable tension
- Industrial process control
- Medical control systems
- Medical equipment testing
- Pharmaceutical process or product control
- Semiconductor/electronics testing
- Aerospace testing

PORTFOLIO

Honeywell's miniature and subminiature load cells are designed to fit into systems and applications with limited space or tight clearances. Constructed of rugged stainless steel for precise measurements and excellent long term stability and reliability under harsh operating conditions, these load cells are designed to eliminate or reduce to a minimum the effect of off-axis loads. To view the entire product portfolio, click [here](#).

Low Range Precision Miniature Load Cells, Model 31 Low

Table 1. Performance Specifications

Characteristic	Measure
Load ranges	0,5 N; 1,5 N; 2,5 N; 5 N 50 g; 150 g; 250 g; 500 g
Linearity	±0.15 % full scale
Hysteresis	±0.15 % full scale
Non-repeatability	±0.1 % full scale
Full scale output (tolerance)	50 g to 150 g 0.1 mV/V/g nominal
	0,5 N to 1,5 N 10 mV/V/N nominal
	2,5 N to 5 N 250 g to 500 g 20 mV/V nominal
Operation	Tension/compression ³
Resolution	Infinite

Table 2. Environmental Specifications

Characteristic	Measure
Temperature, operating	-55 °C to 125 °C [-67 °F to 257 °F]
Temperature, compensated	15 °C to 71 °C [60 °F to 160 °F]
Storage temperature	-73 °C to 148 °C [-100 °F to 300 °F]
Temperature effect, zero	±0.03 % full scale/°C [±0.015 % full scale/°F]
Temperature effect, span	±0.03 % reading/°C [±0.015 % reading/°F]

Table 3. Electrical Specifications

Characteristic	Measure
Strain gage type	Semiconductor
Excitation (calibration)	5 Vdc
Insulation resistance	5000 Mohm @ 50 Vdc
Bridge resistance (tolerance)	500 ohm (nominal)
Zero balance	±1 %FS max.
Electrical termination (std)	Teflon [®] cable (1,5 m [5 ft])

Table 4. Mechanical Specifications

Characteristic	Measure
Maximum allowable load	20 N [5 lb] ¹
Weight	90 g
Material	17-4 PH stainless steel
Deflection full scale	0,020 mm [0.0008 in]
Natural frequency	740 Hz

Table 5. Wiring Codes

Cable	
Red	(+) excitation
Black	(-) excitation
Green	(-) output
White	(+) output

Table 6. Range Codes

Range Codes	Range	Range Codes	Range
AJ	50 g	MD	0,5 N
AL	150 g	NJ	1,5 N
AN	250 g	NK	2,5 N
AP	500 g	MG	5 N

Table 7. Option Codes

	Many range/option combinations are available in our quick-ship and fast-track manufacture programs. Please click here for updated listings.
Load range	50 g; 150 g; 250 g; 500 g; 0,5 N; 1,5 N; 2,5 N; 5 N
Temperature compensation	1a. 15 °C to 71 °C [60 °F to 160 °F] 1c. -18 °C to 85 °C [0 °F to 185 °F]
Internal amplifiers	2u. Unamplified, mV/V output
Overload stops	4a. Overload stop
Electrical termination	6e. Integral cable: Teflon [®]
Electrical connector orientation	15c. Radial electrical exit port orientation
Special calibration³	30a. Compression only calibration, positive in compression 30b. Tension and compression calibration, positive in tension 30d. Tension and compression calibration, positive in compression
Mounting interfaces⁴	(none) #6-32 UNC 32b. M4 x 0.7
Electrical Interfaces⁵	53s. Phoenix connector with Signature Calibration module ⁶ 53t. TEDS IEEE 1451.4 module ⁷

Low Range Precision Miniature Load Cells, Model 31 Low

Figure 1. Mounting Dimensions

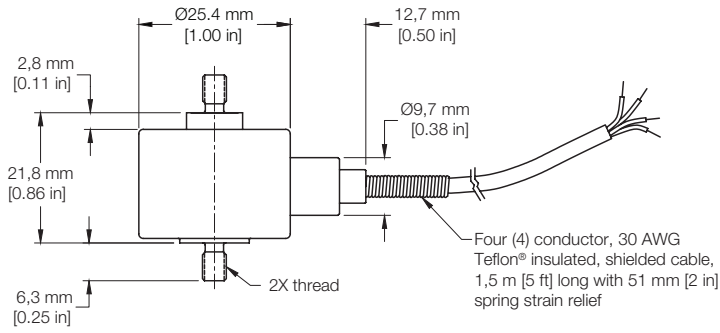

Figure 2. Typical System Diagram

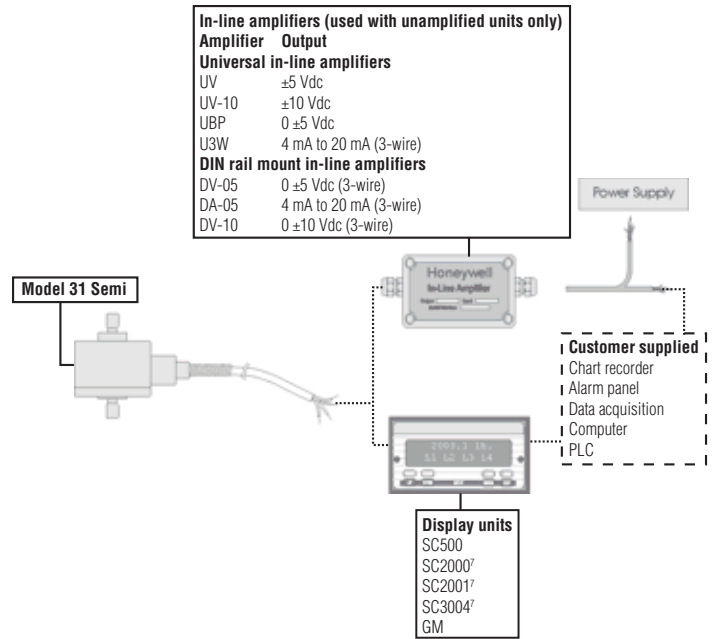

Figure 3. Product Nomenclature

	AL311	MD	1A	2U	4A	6E	15C		32B	
	Load Type	Range	Temperature Compensation	Internal Amplifiers	Overload Stops	Electrical Termination	Electrical Conn. Orientation	Special Calibration ³	Mounting Threads ⁴	Calibration Memory ⁵
Model 31 Low		MD 0.5 Newton	1A 15 °C to 71 °C [60 °F to 160 °F]	2U Unamplified, mV/V output	4A Overload stop	6E Teflon®, Integral cable	15C Radial exit	Tension only (+)	#6-32 UNC (none)	No storage (none)
Precision Miniature Load Cell		NJ 1.5 Newton	1C -18 °C to 85 °C [0 °F to 185 °F]					30A Compression only (+)	32B M4 x 0.7	53S Phoenix connector with Signature Calibration Module
		NK 2.5 Newton						30B Tension (+) and Compression (-)		53T TEDS IEEE 1451.4 module
		MG 5 Newton						30D Tension (-) and Compression (+)		
		AJ 50 grams								
		AL 150 grams								
		AN 250 grams								
		AP 500 grams								

NOTES

1. Allowable maximum loads - maximum load to be applied without damage.²
2. Without damage - loading to this level will not cause excessive zero shift or performance degradation. The user must consider fatigue life or long term use and structural integrity. All structurally critical applications (overhead loading, etc.) should always be designed with safety redundant load paths.
3. Standard calibration for tension/compression load cells is in tension only.
4. For gram ranges, the default thread will be #6-32 UNC. For newton ranges, the default thread will be M4 x 0.7, and will be designated in the order code string by option 32B.
5. Maximum operating temperature for options 53s and 53t is 85 °C [185 °F]
6. For use with the SC2000 and SC3000 Series instruments, output would be limited to 11 mV/V for compatibility. Consult factory.
7. TEDS IEEE 1451.4 module installed at end of cable.

Find out more

Honeywell serves its customers through a worldwide network of sales offices, representatives and distributors. For application assistance, current specifications, pricing or name of the nearest Authorized Distributor, contact your local sales office.

To learn more about Honeywell's test and measurement products, call **+1-815-235-6847** or **1-800-537-6945**, visit **sensing.honeywell.com**, or e-mail inquiries to **info.tm@honeywell.com**

Honeywell Safety and Productivity Solutions

9680 Old Bailes Road
Fort Mill, SC 29707
honeywell.com

WARNING **PERSONAL INJURY**

DO NOT USE these products as safety or emergency stop devices or in any other application where failure of the product could result in personal injury.

Failure to comply with these instructions could result in death or serious injury.

WARNING **MISUSE OF DOCUMENTATION**

- The information presented in this product sheet is for reference only. Do not use this document as a product installation guide.
- Complete installation, operation, and maintenance information is provided in the instructions supplied with each product.

Failure to comply with these instructions could result in death or serious injury.

Warranty/Remedy

Honeywell warrants goods of its manufacture as being free of defective materials and faulty workmanship. Honeywell's standard product warranty applies unless agreed to otherwise by Honeywell in writing; please refer to your order acknowledgement or consult your local sales office for specific warranty details. If warranted goods are returned to Honeywell during the period of coverage, Honeywell will repair or replace, at its option, without charge those items it finds defective.

The foregoing is buyer's sole remedy and is in lieu of all other warranties, expressed or implied, including those of merchantability and fitness for a particular purpose. In no event shall Honeywell be liable for consequential, special, or indirect damages.

While we provide application assistance personally, through our literature and the Honeywell web site, it is up to the customer to determine the suitability of the product in the application.

Specifications may change without notice. The information we supply is believed to be accurate and reliable as of this printing. However, we assume no responsibility for its use.

Honeywell