

IP Series

Industrial Pressure Sensor Platform



DESCRIPTION

Honeywell's Industrial Pressure (IP) series is a new platform of general purpose pressure sensors designed to offer repeatable, reliable, and accurate pressure measurements over time. These rugged, stainless steel, all-welded pressure sensors are pre-configured with tailored features and options for a wide range of demanding applications. All models are designed to work with a variety of media and built to provide consistent performance in harsh environments.

Configurations for voltage and current measurements are fully temperature compensated and calibrated for pressure ranges from 0.5 bar to 700 bar and 5 psi to 10K psi.

Customers can choose from two different accuracies to meet their specific application requirements:

IPG1 offers ± 0.15 % BFSL (Best Fit Straight Line) accuracy

IPG2 offers ± 0.25 % BFSL (Best Fit Straight Line) accuracy

FEATURES

- Rugged design - all welded, 300 series stainless steel and Hastelloy®
- Accuracy options: ± 0.15 %, ± 0.25 % BFSL
- Voltage outputs
- Current output
- Total error band that includes non-linearity, repeatability and hysteresis as well as temperature error.
- Pre-configured pressure sensor package with most commonly requested options
- IP65 rated for protection for harsh environments
- <2 ms response time provides accurate, high-speed measurement
- CE and RoHS compliant*

APPLICATIONS

- General industrial process control
- Factory automation/Industrial equipment
- Medical equipment systems
- Pump/Compressor control
- Power generation
 - Wind
 - Propulsion
- Transportation
 - Construction equipment
 - Rail equipment testing

* RoHS compliant for 100 psi to 5000 psi [7 bar to 350 bar]

IP Series

TABLE 1. PRESSURE RANGE SPECIFICATIONS (AT 25 °C [77 °F])

psi (gauge)									
Pressure	5	10	15	25	30	50	75	100	150
Proof pressure	20	40	60	100	120	200	300	400	450
Burst pressure	1000	1000	1000	1000	1000	1000	1000	1000	1500

psi (gauge)										
Pressure	200	250	500	750	1000	1500	3000	5000	7500	10000
Proof pressure	600	750	1500	2250	2000	3000	6000	7500	15000	15000
Burst pressure	2000	2500	5000	7500	10000	15000	30000	30000	15000	15000

bar (gauge)									
Pressure	0.5	1	2	3.5	4	7	10	16	25
Proof pressure	2	4	8	14	16	28	30	48	75
Burst pressure	100	100	100	100	100	100	100	160	250

bar (gauge)							
Pressure	40	60	100	160	250	350	700
Proof pressure	80	120	200	320	500	700	1000
Burst pressure	400	600	1000	1600	2068	2068	1000

TABLE 2. PHYSICAL AND ENVIRONMENTAL SPECIFICATIONS

Parameter	Characteristic
Material in contact with media	Port: 300 Series stainless steel, Hastelloy®
Housing material	300 Series stainless steel
Weight	
100 psi to 5000 psi	158 g [5.6 oz] (1/4 BSP port with DIN 43650)
5 psi to 75 psi and 7500 psi to 10000 psi (0.5 bar to 3.5 bar, 700 bar)	186 g [6 oz] (1/4 BSP port with DIN 43650)
Shock	100 g peak [11 ms]
Vibration	MIL-STD-810C, Figure 514.2-5, Curve AK, Table 514.2-V, Random Vibration Test [overall g rms = 20.7 min.]
Compensated temperature range	
100 psi to 5000 psi	-10 °C to 85 °C [14 °F to 185 °F]
5 psi to 75 psi and 7500 psi to 10000 psi (0.5 bar to 3.5 bar, 700 bar)	4 °C to 60 °C [40 °F to 140 °F]
Operating & storage temperature range	-40 °C to 125 °C [-40 °F to 257 °F]
Approvals	CE, RoHS* (*RoHS compliant for 100 psi to 5000 psi [7 bar to 350 bar])

Industrial Pressure Sensor Platform

TABLE 3. ELECTRICAL SPECIFICATIONS (AT 25 °C [77 °F] AND A RATED EXCITATION UNLESS OTHERWISE NOTED)

Parameter	Current	Regulated	Regulated
Zero output	4 mA	0.25 Vdc	0.5 Vdc
Full scale span (FSS)	16 mA (4 mA to 20 mA)	10 Vdc (0.25 Vdc to 10.25 Vdc)	4 Vdc (0.5 Vdc to 4.5 Vdc)
Excitation	9.5 Vdc to 30 Vdc	14 Vdc to 30 Vdc	7 Vdc to 30 Vdc
Supply current	N/A	5 mA typ. (17 mA max.)	5 mA typ. (17 mA max.)
Source (nominal)	N/A	1 mA	1 mA
Sink (nominal)	N/A	1 mA at zero output	1 mA at zero output
Supply rejection ratio	90 dB	90 dB	90 dB
Output impedance	N/A	25 Ω max.	25 Ω max.

TABLE 4. PERFORMANCE SPECIFICATIONS (AT 25 °C [77 °F] AND A RATED EXCITATION UNLESS OTHERWISE NOTED)

Parameter	Characteristic
Response time	<2 ms
Accuracy ¹	±0.15 % BFSL ±0.25 % BFSL
Total error band ²	±2 % FS

Notes:

1. Includes pressure non-linearity (BFSL), pressure hysteresis and non-repeatability. Thermal errors are not included.
2. Includes zero error, span error, thermal effect on zero, thermal effect on span, thermal hysteresis, pressure-non-linearity, pressure hysteresis and non-repeatability

LISTINGS

These are examples of common configurations that are available. Please refer to the “Nomenclature and Order Guide” in the data sheet for all possible product configurations. Order via Test and Measurement’s web site <http://measurementsensors.honeywell.com> or call our Inside Sales Team +1 614-850-5000 or 1-800-848-6564.

Order codes	Description
IPG1BR,1BA, 2Y, 5F, 6M	Model IP, 0.15 % accuracy, 100 psi, -10 °C to 85 °C [14 °F to 185 °F], 4 mA to 20 mA, 1/4 B Female, DIN 43650 connector
IPG1CN,1BA, 2Y, 5F, 6M	Model IP, 0.15 % accuracy, 250 psi, -10 °C to 85 °C [14 °F to 185 °F], 4 mA to 20 mA, 1/4 B Female, DIN 43650 connector
IPG1BR,1BA, 2AC, 5F, 6M	Model IP, 0.15 % accuracy, 100 psi, -10 °C to 85 °C [14 °F to 185 °F], 0.5 Vdc to 4.5 Vdc, 1/4 B Female, DIN 43650 connector
IPG1CN,1BA, 2AC, 5F, 6M	Model IP, 0.15 % accuracy, 250 psi, -10 °C to 85 °C [14 °F to 185 °F], 0.5 Vdc to 4.5 Vdc, 1/4 B Female, DIN 43650 connector
IPG1NB,1BA, 2Y, 5F, 6M	Model IP, 0.15 % accuracy, 7 bar, -10 °C to 85 °C [14 °F to 185 °F], 4 mA to 20 mA, 1/4 B Female, DIN 43650 connector
IPG1NY,1BA, 2Y, 5F, 6M	Model IP, 0.15 % accuracy, 16 bar, -10 °C to 85 °C [14 °F to 185 °F], 4 mA to 20 mA, 1/4 B Female, DIN 43650 connector
IPG1NB,1BA, 2AC, 5F, 6M	Model IP, 0.15 % accuracy, 7 bar, -10 °C to 85 °C [14 °F to 185 °F], 0.5 Vdc to 4.5 Vdc, 1/4 B Female, DIN 43650 connector
IPG1NY,1BA, 2AC, 5F, 6M	Model IP, 0.15 % accuracy, 16 bar, -10 °C to 85 °C [14 °F to 185 °F], 0.5 Vdc to 4.5 Vdc, 1/4 B Female, DIN 43650 connector

IP Series

ORDER CODE NOMENCLATURE

Combine the order code and options code.

IPG1BR

1BA,2Y,5F,6M

Order code

Options code

IPG	1	BR	1BA	2Y	5F	6M
Pressure Type	Accuracy	Range	Temperature Compensation	Electrical Output	Pressure Connection	Electrical Termination
IPG Gauge	1 0.15 %	AT 5 psi	1BA -10 °C to 85 °C [14 °F to 185 °F] *	2AC 0.5 Vdc to 4.5 Vdc, CE approved	5B 1/4in-18 NPT male	6M DIN 43650 standard
	2 0.25 %	AV 10 psi	1AK 4 °C to 60 °C [40 °F to 140 °F] **	2AD 0.25 Vdc to 10.25 Vdc, CE approved	5D 7/16in-20 UNF male	6N DIN 40050 (Mini)
		BJ 15 psi	* 100 psi to 5000 psi available in -10 °C to 85 °C [14 °F to 185 °F]	2Y 4 mA to 20 mA, two wire, CE approved	5F 1/4 B female	
		BL 25 psi	** 5 psi to 75 psi and 7500 psi to 10000 psi (0.5 bar to 3.5 bar, 700 bar) available in 4 °C to 60 °C [40 °F to 140 °F]		5G 1/4 B male	
		BM 30 psi				
		BN 50 psi				
		BP 75 psi				
		BR 100 psi				
		CJ 150 psi				
		CL 200 psi				
		CN 250 psi				
		CR 500 psi				
		CT 750 psi				
		CV 1000 psi				
		DJ 1500 psi				
		DL 2000 psi				
		DN 3000 psi				
		DR 5000 psi				
		DT 7500 psi				
		DV 10000 psi				

Industrial Pressure Sensor Platform

ORDER CODES

Order code	Description
IPG1	0.15 % pressure accuracy
IPG2	0.25 % pressure accuracy

RANGE CODES

Range Code	Available ranges
AT	5 psi
AV	10 psi
BJ	15 psi
BL	25 psi
BM	30 psi
BN	50 psi
BL	75 psi
BR	100 psi
CJ	150 psi
CL	200 psi
CN	250 psi
CR	500 psi
CT	750 psi
CV	1000 psi
DJ	1500 psi
DL	2000 psi
DN	3000 psi
DR	5000 psi
DT	7500 psi
DV	10000 psi
MD	0.5 bar
ME	1 bar
MF	2 bar
NA	3.5 bar
NB	7 bar
MH	10 bar
NY	16 bar
NZ	25 bar
PB	40 bar
PC	60 bar
ML	100 bar
PD	160 bar
NL	250 bar
NG	350 bar
NH	700 bar

OPTION CODES

Available Ranges	5 psi, 10 psi, 15 psi, 25 psi, 30 psi, 50 psi, 75 psi, 100 psi, 150 psi, 200 psi, 250 psi, 500 psi, 750 psi, 1000 psi, 1500 psi, 2000 psi, 3000 psi, 5000 psi, 7500 psi, 10000 psi, 0.5 bar, 1 bar, 2 bar, 3.5 bar, 7 bar, 10 bar, 16 bar, 25 bar, 40 bar, 60 bar, 100 bar, 160 bar, 250 bar, 350 bar, 700 bar
Temperature Compensation	1BA. -10 °C to 85 °C [14 °F to 185 °F] * 1AK. 4 °C to 60 °C [40 °F to 140 °F] **
Electrical Output	2AC. 0.5 Vdc to 4.5 Vdc, CE approval 2AD. 0.25 Vdc to 10.25 Vdc, CE approval 2Y. 4 mA to 20 mA, two wire, CE approval
Pressure Connection	5B. 1/4 in-18 NPT male 5D. 7/16 in-20 UNF male 5F. 1/4 B female 5G. 1/4 B male
Electrical Termination	6M. DIN 43650 standard 6N. DIN 40050 (mini)

* 100 psi to 5000 psi available in -10 °C to 85 °C [14 °F to 185 °F]

** 5 psi to 75 psi and 7500 psi to 10000 psi (0.5 bar to 3.5 bar, 700 bar) available in 4 °C to 60 °C [40 °F to 140 °F]

PIN OUTS

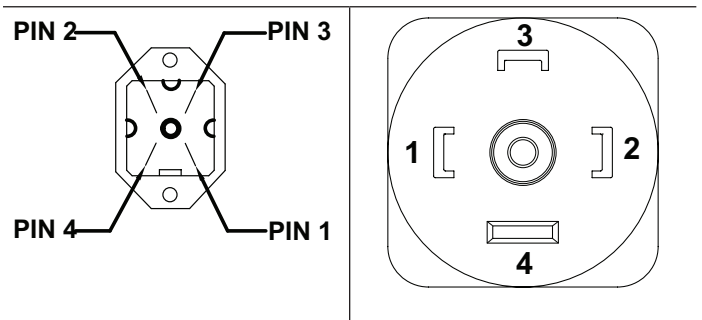

DIN 40050 (Hirschmann), 4-pin

DIN 43650, 4-pin

Regulated

1.) + Power	1.) + Power
2.) + Output	2.) + Output
3.) Common	3.) Common
4.) NC	4.) NC

Current

1.) + Power	1.) + Power
2.) + Output	2.) + Output
3.) NC	3.) NC
4.) NC	4.) NC

Note: Ranges > 1000 psi and 100 bar - end users should take appropriate steps to ensure safety with respect to pressure port attachment.

IP Series

FIGURE 1. MOUNTING DIMENSIONS (FOR PRESSURE RANGES 100 PSI TO 5000 PSI)

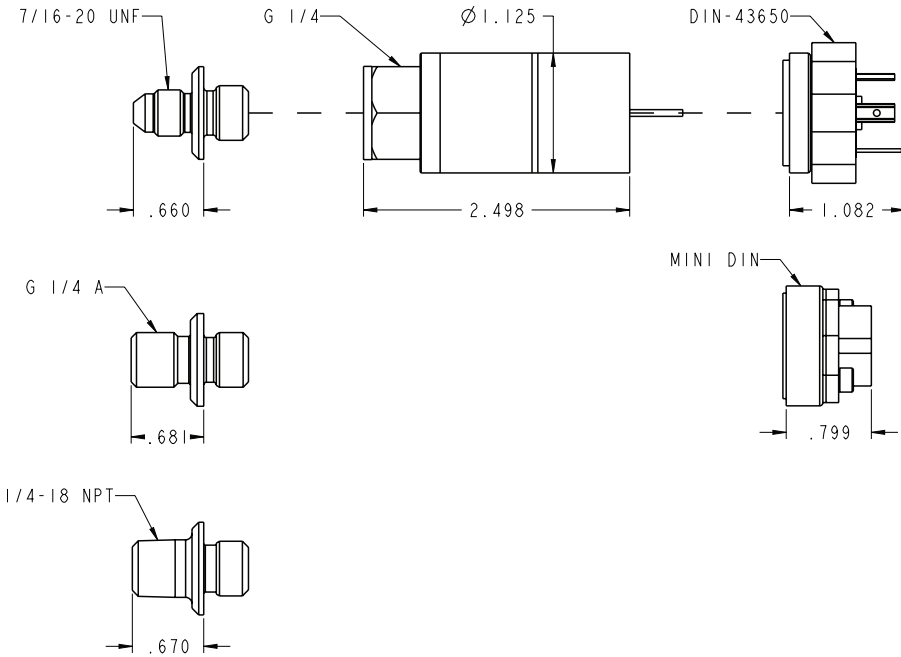
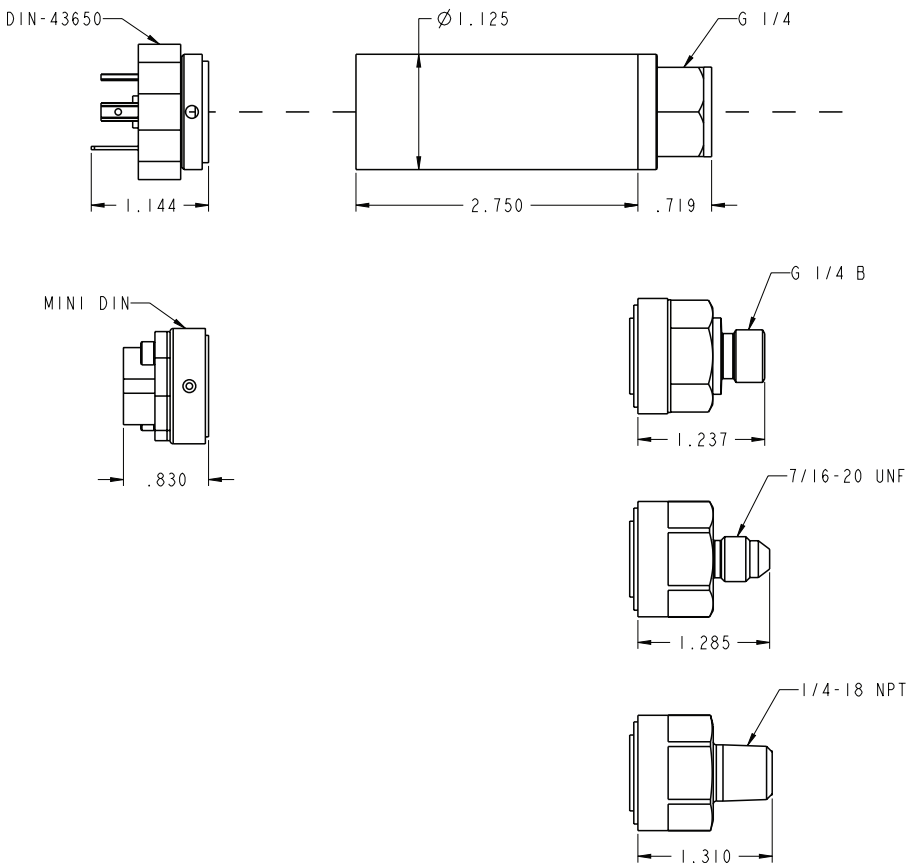

FIGURE 2. MOUNTING DIMENSIONS (FOR PRESSURE RANGES 5 PSI TO 75 PSI, 7500 PSI, AND 10000 PSI)



Warranty. Honeywell warrants goods of its manufacture as being free of defective materials and faulty workmanship. Honeywell's standard product warranty applies unless agreed to otherwise by Honeywell in writing; please refer to your order acknowledgement or consult your local sales office for specific warranty details. If warranted goods are returned to Honeywell during the period of coverage, Honeywell will repair or replace, at its option, without charge those items it finds defective. **The foregoing is buyer's sole remedy and is in lieu of all warranties, expressed or implied, including those of merchantability and fitness for a particular purpose. In no event shall Honeywell be liable for consequential, special, or indirect damages.**

While we provide application assistance personally, through our literature and the Honeywell web site, it is up to the customer to determine the suitability of the product in the application.

Specifications may change without notice. The information we supply is believed to be accurate and reliable as of this printing. However, we assume no responsibility for its use.

WARNING

PERSONAL INJURY

- DO NOT USE these products as safety or emergency stop devices or in any other application where failure of the product could result in personal injury.

Failure to comply with these instructions could result in death or serious injury.

WARNING

MISUSE OF DOCUMENTATION

- The information presented in this datasheet is for reference only. DO NOT USE this document as product installation information.
- Complete installation, operation and maintenance information is provided in the instructions supplied with each product.

Failure to comply with these instructions could result in death or serious injury.

Find out more

Honeywell serves its customers through a worldwide network of sales offices, representatives and distributors. For application assistance, current specifications, pricing or name of the nearest Authorized Distributor, contact your local sales office. To learn more about Honeywell's test and measurement products, call **+1-614-850-5000**, visit **<http://measurementsensors.honeywell.com>**, or e-mail inquiries to **info.tm@honeywell.com**

Sensing and Control
Honeywell
1985 Douglas Drive North
Golden Valley, MN 55422
www.honeywell.com

008889-1-EN IL50 GLO
May 2012
Copyright © 2012 Honeywell International Inc. All rights reserved.
Hastelloy® is the registered trademark name of Haynes International, Inc.

Honeywell