

T6120A,B

SINGLE- AND DUAL-STAGE INDUSTRIAL ROOM THERMOSTATS

SPECIFICATION DATA AND MOUNTING INSTRUCTIONS



GENERAL

The T6120A and B Single- and Dual-Stage Industrial Room Thermostats are designed for measuring, monitoring, and controlling temperatures in heating and cooling systems. These thermostats are suitable for the following areas of applications:

- commercial buildings,
- storage rooms,
- garages,
- machine rooms,
- factories,
- greenhouses, and
- agricultural installations.

FEATURES

- Liquid-filled stainless steel or copper (T6120A1005, only) bulb.
- Rugged design.
- Easy installation and wiring connection.
- Dust-tight microswitches with switching contacts for heating and cooling.

MODELS

	T6120A1005	T6120A1013	T6120A1021	T6120A1039	T6120B1003
no. of stages	1				2
switch contact	1 SPDT				2 SPDT
hysteresis	1 K (fixed)	2...15 K (adjustable)		1 K (fixed)	1 K (fixed)
switching differential between stages	n.a.				2...10 K (adjustable)
adjustment range	0...60 °C		-30...+30 °C		
working temperature	-10...+65 °C	-35...+65 °C			
storage temperature	-20...+70 °C				
current	10 (1.5) A	15 (8) A			
voltage	250 Vac	24...250 Vac			
housing	ABS, re-inforced				
sensor material	1.4301	copper			
weight	360 g	530 g			
protection standard	IP54	IP65			
W x H x L (mm)	108 x 70 x 72				

T6120A1005

Function and Wiring

To control a heating unit, connect terminals 2 and 3 of the thermostat to the heating unit. When the temperature rises, the contact will open (see Fig. 1).

To control a cooling unit, connect terminals 1 and 2 of the thermostat to the cooling unit. When the temperature drops, the contact will open (see Fig. 1).

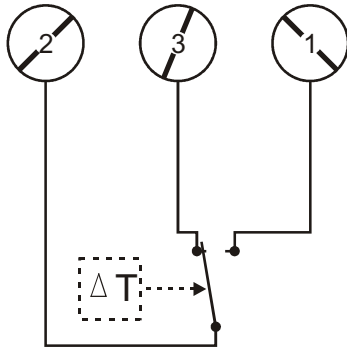

Fig. 1. T6120A1005 wiring

Dimensions

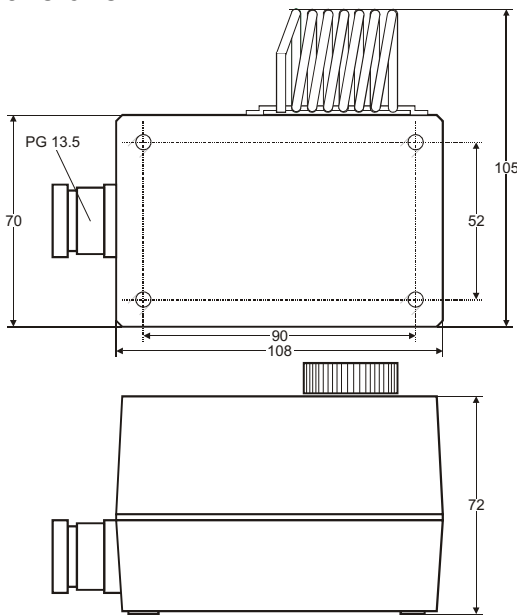

Fig. 2. Dimensions T6120A1005 (in mm)

T6120A1013/A1021/A1039

Function and Wiring

To control a heating unit, connect the red terminal ("COMMON") and the blue terminal ("NORM OPEN") of the thermostat to the heating unit. When the temperature rises, the contact will open (see Fig. 3).

To control a cooling unit, connect the red terminal ("COMMON") and white terminal ("NORM CLOSED") of the thermostat to the cooling unit. When the temperature drops, the contact will open (see Fig. 3).

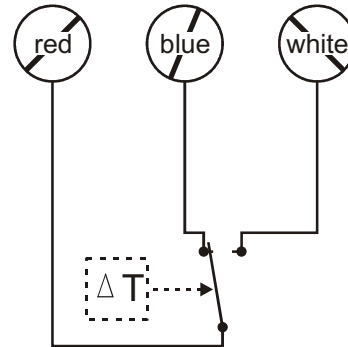

Fig. 3. Wiring T6120A1013/1021/1039 and T6120B1003

Adjusting the Hysteresis (T6120A1013/A1021, only)

In the case of the T6120A1013/A1021 Single-Stage Thermostats, it is possible to adjust the hysteresis to a value of between 2 K (factory setting) and 15 K. This can be done as follows:

Pull off the adjustment knob, unscrew the two fastening screws, and remove the housing cover. The hysteresis adjustment dial is now visible (see Fig. 4). The dial settings are numbered from "2" (corresponding to the min. setting of 2 K) to "15" (corresponding to the max. setting of 15 K).

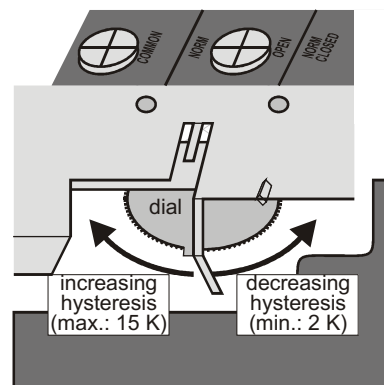

Fig. 4. Adjusting the hysteresis (T6120A1013/A1021, only)

Dimensions

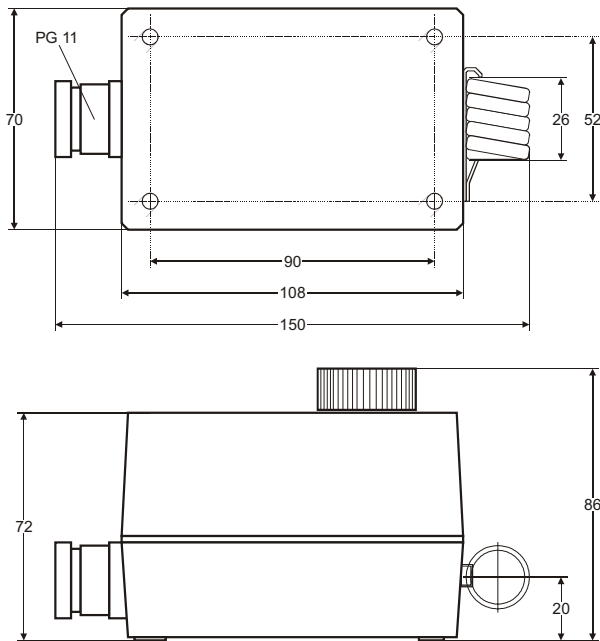

Fig. 5. Dimensions T6120A1013/A1021/A1039 and T6120B1003 (in mm)

T6120B1003

Function and Wiring

To control a heating unit, connect the red terminal and the blue terminal of both stages of the thermostat to the corresponding terminals of the heating unit (see Fig. 6). When the temperature rises, the contact of stage 1 will open; if the temperature rises an additional value corresponding to the set switching differential (see section "Adjusting the Switching Differential between Stages"), the contact of stage 2 will then likewise open.

To control a cooling unit, connect the red terminal and white terminal of both stages of the thermostat to the corresponding terminals of the cooling unit (see Fig. 6). When the temperature drops, the contact of stage 1 will open; if the temperature drops an additional value corresponding to the set switching differential (see section "Adjusting the Switching Differential between Stages"), the contact of stage 2 will then likewise open.

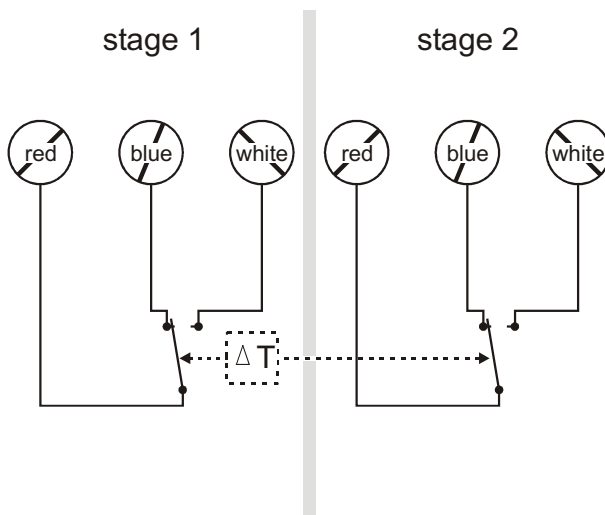

Fig. 6. Wiring T6120B1003

Adjusting the Switching Differential between Stages

In the case of the T6120B1003 Dual-Stage Thermostat, it is possible to adjust the switching differential (i.e. the difference in temperatures at which the two stages are activated) to a value of between 2 K (factory setting) and 10 K. This can be done as follows:

Pull off the adjustment knob, unscrew the two fastening screws, and remove the housing cover. The switching differential adjustment lever is now visible (see). Sliding the lever to the right increases (max.: 10 K) the switching differential. Sliding it to the left decreases (min.: 2 K) the switching differential.

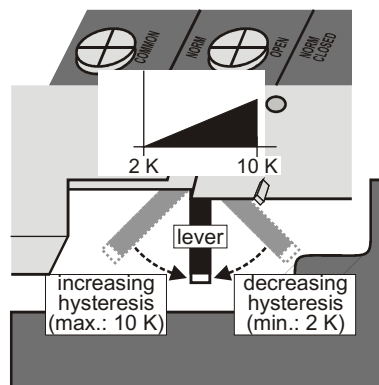

Fig. 7. Adjusting the switching differential

Honeywell

Automation and Control Solutions

Honeywell GmbH
P.O. Box 1254
D-71099 Schönaich
Phone: (49) 7031-637-02
Fax: (49) 7031-637-850
<http://honeywell.de/fema>

Subject to change without notice. Printed in Germany
EN0B-0317GE51 R0304

Manufacturing location certified to **DIN EN**
ISO 9001