

Model TMS 9250

Shaft-to-Shaft Torque Measurement System

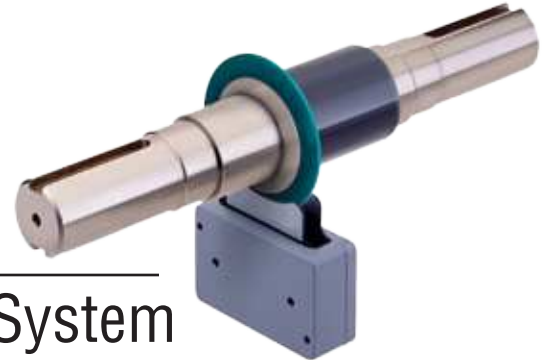

DESCRIPTION

Honeywell's TMS 9250 torque measurement system provides a non-contact torque measurement through digital telemetry on rotating parts. The TMS 9250's fully digital, wireless design enables higher integrity of the torque data capture through higher resolution, higher sensitivity, faster response, and no mechanical interferences. The result is a more accurate indication of the actual torque being experienced, plus an increase in reliability. This digital wireless telemetry system also supplies excitation power to the rotating sensor across the gap, supports two-way communications, and supports virtually unlimited testing capabilities.

Honeywell's modular design can easily be adapted or customized to fit into many different types of test stands to meet specific test application requirements. The TMS 9250 is durable and compact in size to fit those tight installations and comes standard with quick attach wiring connectors for rapid commissioning. The TMS 9250 physically integrates rotor electronics and telemetry into one element. With no slip rings or bearings to replace, the TMS 9250 saves time with less routine maintenance.

FEATURES

- Digital telemetry, non-contact
- 0.05% full scale, total system accuracy
- Shaft-to-shaft compatible
- 50 ft-lb to 200000 ft-lb [100 Nm to 271164 N-m] capacity
- High torsional stiffness
- Low rotating inertia
- Multiple, field selectable, analog outputs
- Scalable output "on the fly"
- Compact, modular design, ideal for customization
- Power supply adapter included (FCC compliant)
- Shunt calibration standard
- Remote shunt calibration option available
- Full software set-up
- No potentiometers or dip switches
- FCC and CE certified, meeting all EMC emission and susceptibility requirements

The TMS 9250's set-up is fully software driven; therefore, it is easily controlled through the computer software and its output type is selectable from the standard voltage, current, and frequency output selections. The TMS 9250 is a fully digital system with no dip-switches or potentiometers. The output can be scaled "on the fly" by the software.

Featuring "on-the-fly" edit capability, setup and operation of the rotating sensor can be controlled by the user at any time. Therefore, the parameters become real-time selectable allowing the user to make the necessary adjustments necessary to change their system without test interruption or affecting the calibration. Finally, all setup parameter and calibration information is stored in files and can be recalled on demand for repeat test conditions.

Honeywell's TMS 9250 is fully FCC, CE certified meeting all EMC emission and susceptibility requirements. This product will not cause RF interference with other equipment.

APPLICATIONS

- Powertrain testing: engine, engine diagnostics, cold engine, transmission, driveshaft, & rear axle differential
- Dynamometer
- Brakes
- Wheel hub
- Drive wheels
- Continuous track, heavy equipment
- Oil & water pump testing
- Jet engine/turbine testing
- Wind power gearbox and torsion blade testing; propeller testing
- Turn up/Turn down gear box testing
- Industrial motor / generator testing
- Auxiliary component efficiency testing



Model TMS 9250

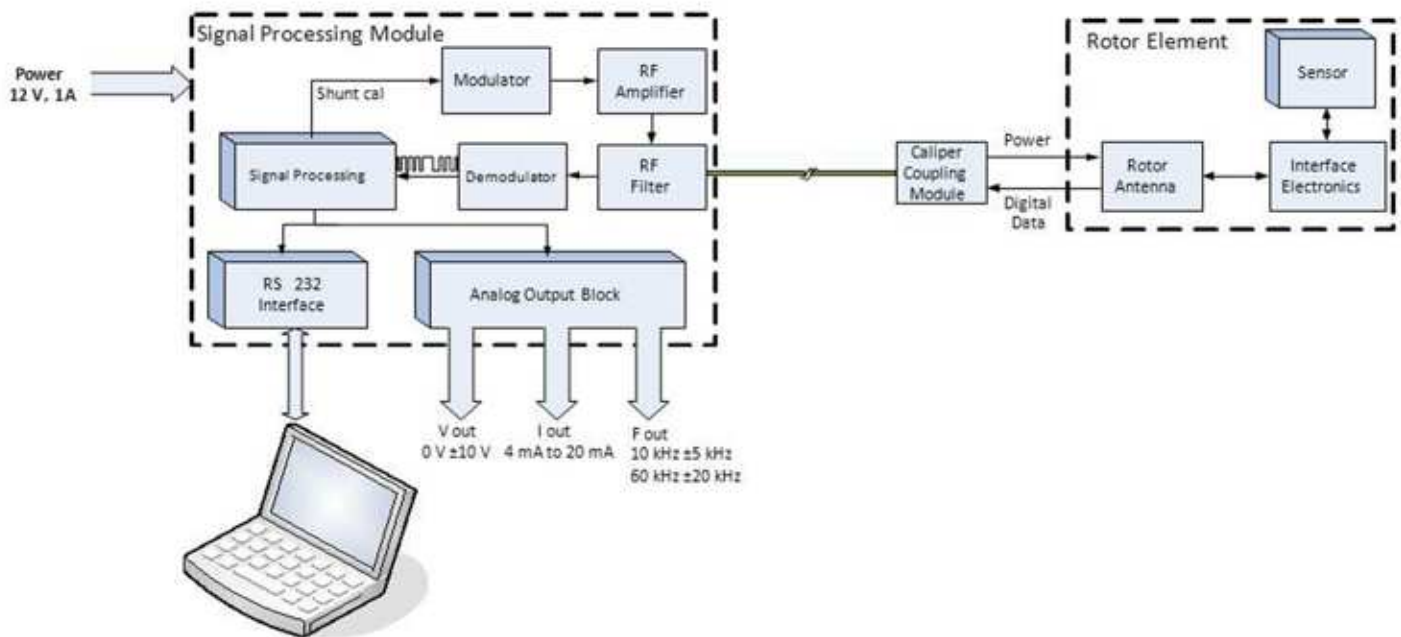

STANDARD SIZES AVAILABLE

- Need sizes here

DYNAMICS OF THE TMS 9250

- The rotor electronics module is encapsulated to enhance protection against vibration, G Force and chemicals
- The rotating antenna is peripherally or centrally mounted on the rotor
- Four layer construction ensures enhanced strength with no exposed tracks in the outer region
- Designed to resist dust and fluid contamination. Provides power transmission and signal recovery via tri-axial cable

ROTOR TRANSMITTER ELECTRONICS (RTE)

The RTE provides bridge excitation power for the torque sensor. Conditions the bridge output signal before transmitting a digitized signal to the SPM.

CALIPER COUPLING MODULE (CCM)

The CCM is a tuned antenna connected to the signal processing module (SPM) RF board through RF tri-axial cable. The CCM is used to wirelessly induce power to the rotor antenna and wirelessly receives the rotor electronics signals to collect torque event data. The antenna is stationary and enables communication between the rotating part and the SPM.

SIGNAL PROCESSING MODULE (SPM)

The SPM contains two separate microprocessors to share data processing and communications. Calibration is all digital characterization, via RS-232 link, eliminating zero and span adjustments, dip switches, and potentiometers. The durable unit has an external BNC connector for the tri-axial cable, internal 2-part plug and socket connectors for output signals, digital communication and dc power. The SPM external housing also features a "SHUNT CAL" button and LEDs to indicate "Power ON", "Rotor Active" and "SHUNT CAL Mode". Because of these enhanced technologies, the end result is a true advancement in telemetry-based torque systems.

SOFTWARE FEATURES

The toolkit software at the heart of the TMS 9250 system is designed to offer flexibility and adaptability. The software puts the operator fully in control and can be tailored to the test conditions required at the time. Standard or custom set ups can be saved to parameter files and recalled at any time. Selectable scaling creates an advantage for the user as it allows coverage of a greater set of applications and test conditions. The software-driven SPM (Signal Processing Module) is offered with eight selectable analog output settings of four settings and eight modes. The software includes zero offset correction, auto zero.

CONFIGURATIONS

All configurations are custom. For more details, please call the factory at +1-614-850-5000 or 800-848-6564.

Model TMS 9250

Shaft-to-Shaft Torque Measurement System

NOTES

* To be FCC/CE compliant, the use of a Honeywell power supply is required.

Find out more

Honeywell serves its customers through a worldwide network of sales offices, representatives and distributors. For application assistance, current specifications, pricing or name of the nearest Authorized Distributor, contact your local sales office. To learn more about Honeywell's test and measurement products, call **+1-614-850-5000**, visit **<http://measurementsensors.honeywell.com>**, or e-mail inquiries to **info.tm@honeywell.com**

Sensing and Control
Honeywell
1985 Douglas Drive North
Golden Valley, MN 55422
www.honeywell.com

Warranty. Honeywell warrants goods of its manufacture as being free of defective materials and faulty workmanship. Honeywell's standard product warranty applies unless agreed to otherwise by Honeywell in writing; please refer to your order acknowledgement or consult your local sales office for specific warranty details. If warranted goods are returned to Honeywell during the period of coverage, Honeywell will repair or replace, at its option, without charge those items it finds defective. **The foregoing is buyer's sole remedy and is in lieu of all warranties, expressed or implied, including those of merchantability and fitness for a particular purpose. In no event shall Honeywell be liable for consequential, special, or indirect damages.**

While we provide application assistance personally, through our literature and the Honeywell web site, it is up to the customer to determine the suitability of the product in the application.

Specifications may change without notice. The information we supply is believed to be accurate and reliable as of this printing. However, we assume no responsibility for its use.

WARNING

PERSONAL INJURY

- DO NOT USE these products as safety or emergency stop devices or in any other application where failure of the product could result in personal injury.

Failure to comply with these instructions could result in death or serious injury.

WARNING

MISUSE OF DOCUMENTATION

- The information presented in this datasheet is for reference only. DO NOT USE this document as product installation information.
- Complete installation, operation and maintenance information is provided in the instructions supplied with each product.

Failure to comply with these instructions could result in death or serious injury.

Honeywell