

Model Z

High Range Wet/Wet Differential Pressure Transducer



DESCRIPTION

The Z High Range Wet/Wet transducers are engineered to measure differential pressures as great as 10k psid and achieve accuracy of 0.25 % full scale. Each is bi-directional and accepts fluid in both ports. 17-4 PH stainless steel ensures durability of these bonded foil strain gage units under harsh industrial conditions.

A variety of standard options are available with the Model Z including choice of pressure adaptors, alternative pressure ports, internal amplifiers options, and electrical terminations.

FEATURES

- 0.25% accuracy
- 2000 psid to 10000 psid
- mV/V (standard), 4 mA to 20 mA, 0 Vdc to 5 Vdc, or 0 Vdc to 10 Vdc output
- Intrinsically safe available (2N option only)¹⁰
- CE approved¹¹

Model Z

PERFORMANCE SPECIFICATIONS

Characteristic	Measure
Pressure ranges	2000, 3000, 5000, 7500, 10000 psid
Accuracy	±0.25 % full scale
Linearity	±0.15 % full scale (typical)
Hysteresis	±0.10 % full scale (typical)
Non-repeatability	±0.05 % full scale (typical)
Output (standard)	2 mV/V (nominal)
Line pressure	2000 psi
Resolution	Infinite

ENVIRONMENTAL SPECIFICATIONS

Characteristic	Measure
Temperature, operating	-54 °C to 121 °C [-65 °F to 250 °F]
Temperature, compensated	15 °C to 71 °C [60 °F to 160 °F]
Temperature, effect, zero	±0.5 % full scale/100 °F
Temperature, effect, span	±0.5 % reading/100 °F

ELECTRICAL SPECIFICATIONS

Characteristic	Measure
Strain gage type	Bonded foil
Excitation (calibration)	10 Vdc
Bridge resistance	350 ohm (nominal)
Shunt calibration data	Included
Elec. termination (std)	PTIH-10-6P or equivalent (hermetic stainless)
Mating connector (not incl.)	PT06A-10-6S or equiv. (AA111)

MECHANICAL SPECIFICATIONS

Characteristic	Measure
Media	Gas, liquid
Overload-safe	number here
2000 psid to 3000 psid	100% over capacity
5000 psid to 10000 psid	50% over capacity
Pressure port	1/4-18 NPT female (2)
Wetted parts material	17-4 PH stainless steel
Case material	Stainless steel

OPTION CODES

Range Code	Many range/option combinations are available in our quick-ship and fast-track manufacture programs. Please see http://sensing.honeywell.com/TMsensorship for updated listings.	
Pressure ranges (psid)	2000, 3000, 5000, 7500, 10000	
Temperature compensation	1a. 60 °F to 160 °F 1b. 30 °F to 130 °F 1c. 0 °F to 185 °F 1d. -20 °F to 130 °F 1e. -20 °F to 200 °F 1f. 70 °F to 250 °F	1g. 70 °F to 325 °F ⁶ 1h. 70 °F to 400 °F ⁶ 1i. -65 °F to 250 °F ⁶ 1j. 0 °C to 50 °C 1m. -25 °C to 110 °C
Internal amplifiers	2u. Unamplified, mV/V output 2b. 4 wire ±5 Vdc 2c. 0 Vdc to 5 Vdc 2t. 0 Vdc to 10 Vdc 2j. 4 mA to 20 mA (three-wire) output	2k. 4 mA to 20 mA (two-wire) output ¹² 2n. (2N) 4 mA to 20 mA (two-wire) intrinsically safe ¹²
Pressure ports ⁵	5a. 1/4-18 NPT female 5c. 7/16-20 UNF female	
Electrical termination	6a. Bendix PTIH-10-6P (or equiv.) 6 pin (max. 250 °F) 6b. MS type connector to mate with MS3106-14S-6S (max. 160 °F) ¹ 6e. Integral cable: Teflon (-54 °C to 245 °C) 6f. Integral cable: PVC (-30 °C to 70 °C)	6g. Integral cable: Neoprene (-20 °C to 80 °C) ¹ 6h. Integral cable: Silicone (-54 °C to 150 °C) 6i. Integral underwater cable (8m [26 ft]) (max. 80 °C) ¹ 6j. 1/2-14 conduit fitting with 1,5 m [5 ft] of 4 conductor PVC cable
Shunt calibration	8a. Precision internal resistor ⁸	
Special calibration	9a. 10 point (5 up/5 down) 20% increments @ 20 °C 9b. 20 point (10 up/10 down) 10% increments @ 20 °C	
Wetted diaphragm	17-4 PH stainless steel	
Bridge type	11a. Square bridge ⁶ 11c. Square & symmetrical bridge ⁶ 11b. Symmetrical bridge ⁶	
Zero and span adjustment	14b. Top access to pots ⁷ 14a. No access to pots	
O ring seals	26a. Metal	
Interfaces	53e. Signature calibration ⁶ 53t. TEDS IEEE 1451.4 module ⁹	

High Range Wet/Wet Differential Pressure Transducer

INTERNAL AMPLIFIERS

Amplifier specifications	Voltage output: Option 2b	Voltage output: Option 2c	Voltage output: Option 2t	Current three-wire: Option 2j	Current two-wire: Option 2k	Intrinsically safe amp: Option 2n (2N)***
Output signal	±5 V	0 V to 5 V or ±5 V @ 5 mA	0 V to 10 V or ±10 V @ 5 mA	4 mA to 20 mA	4 mA to 20 mA	4 mA to 20 mA
Input power (voltage)	±15 V or 26 Vdc to 32 Vdc	11 Vdc to 28 Vdc	15 Vdc to 28 Vdc	22 Vdc to 32 Vdc	9 Vdc to 32 Vdc	9 Vdc to 28 Vdc
Input power (current)	45 mA	40 mA	40 mA	65 mA	4 mA to 28 mA	4 mA to 24 mA
Freq. resp (amp)	3000 Hz	3000 Hz	3000 Hz	2500 Hz	300 Hz	2000 Hz
Power supply rej.	60 db	60 db	60 db	60 db	60 db	60 db
Operating temp.	-20 °F to 185 °F	-20 °F to 185 °F	-20 °F to 185 °F	0 °F to 185 °F	0 °F to 185 °F	-20 °F to 185 °F
Reverse voltage protection	Yes	Yes	Yes	Yes	Yes	Yes
Short cir. protection	Momentary	Momentary	Momentary	Yes	Yes	Yes
Wiring code: connector (std) ²	A (+) Supply B Output common C Supply return D (+) Output E Shunt cal 1 F Shunt cal 2	A (+) Supply B Output common** C Supply return ** D (+) Output E Shunt cal 1 F Shunt cal 2	A (+) Supply B Output common** C Supply return** D (+) Output E Shunt cal 1 F Shunt cal 2	A (+) Supply B Output common** C Supply return** D (+) Output E Shunt cal 1 F Shunt cal 2	A (+) Supply B No connection C No connection D (+) Output E Case ground F No connection	A (+) Supply B No connection C No connection D (+) Output E Case ground F No connection
Wiring code: cable ^{2,3,4}	R (+) Supply BI Output common G Supply return W (+) Output B Shunt cal 1 Br Shunt cal 2	R (+) Supply BI Output common* G Supply return* W (+) Output B Shunt cal 1 Br Shunt cal 2	R (+) Supply BI Output common* G Supply return* W (+) Output B Shunt cal 1 Br Shunt cal 2	R (+) Supply BI Output common* G Supply return* W (+) Output B Shunt cal 1 Br Shunt cal 2	R (+) Supply BI (+) Output W Case ground	R (+) Supply BI (+) Output W Case ground

* Black and green wires are internally connected.

** Pins B and C are internally connected.

MOUNTING DIMENSIONS AND CHARACTERISTICS

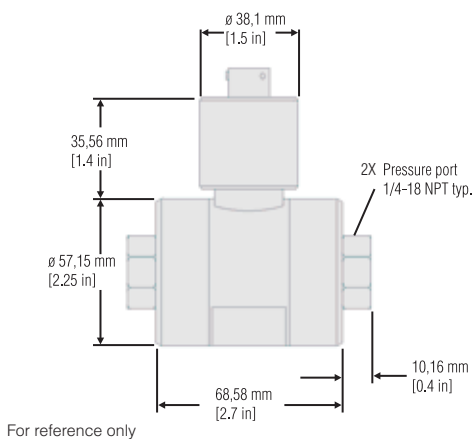

TYPICAL SYSTEM DIAGRAM

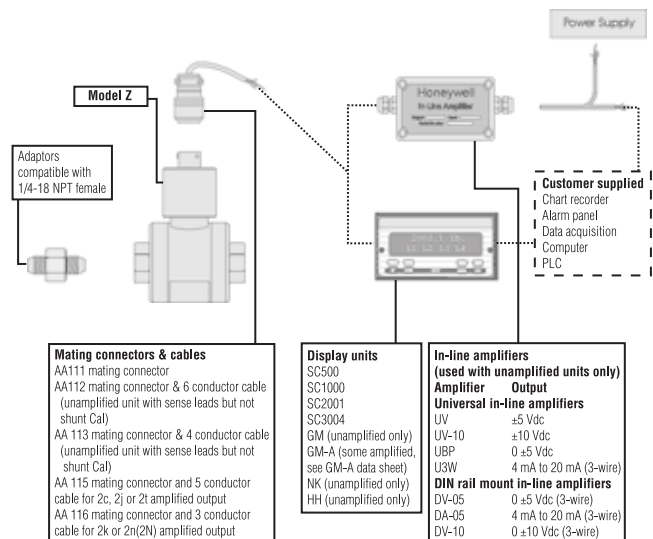

Model Z

High Range Wet/Wet Differential Pressure Transducer

RANGE CODES

Range Code	Available ranges
DL	±2000 psid
DN	±3000 psid
DR	±5000 psid
DT	±7500 psid
DV	±10000 psid

WIRING CODES

Connector	Unamplified
A, B	(+) excitation
C, D	(-) excitation
E	(-) output
F	(+) output

NOTES

1. Availability varies according to range.
2. Interconnecting shunt cal. 1 terminal with shunt cal. 2 terminal provides 50% (unamplified units), 75% (4 mA to 20 mA 3-wire units) or 80% (voltage amplified units of full scale output for quick calibration. Shunt calibration comes standard with internal amplifier options 2b, 2c, 2t and 2j.
3. O=Orange, Y=Yellow, B=Blue, Bl=Black, R=Red, Br=Brown, W=White, G=Green. Color specifying cable and number or letter specifying connector.
4. No mating connector necessary for cable option.
5. Some pressure port options may require axial orientation.
6. Only available with unamplified option 2u.
7. Only available with amplified options.
8. Only available with Vdc output options 2b, 2c.
9. Consult factory for TEDS availability with amplified models.
10. Range dependent; consult factory. Termination dependent; consult factory.
11. Internal amp and termination dependent; consult factory.
12. 5000 ohm bridge required.

Note: Unless otherwise specified on order, amplified units with 4 mA to 20 mA output will provide 4 mA at 0 psid and 20 mA at positive full scale and the unit will not operate in the negative direction. An available alternative is to specify 4 mA at negative full scale and 20 mA at positive full scale. All amps add 2 in to amplifier housing.

Warranty. Honeywell warrants goods of its manufacture as being free of defective materials and faulty workmanship. Honeywell's standard product warranty applies unless agreed to otherwise by Honeywell in writing; please refer to your order acknowledgement or consult your local sales office for specific warranty details. If warranted goods are returned to Honeywell during the period of coverage, Honeywell will repair or replace, at its option, without charge those items it finds defective. **The foregoing is buyer's sole remedy and is in lieu of all warranties, expressed or implied, including those of merchantability and fitness for a particular purpose. In no event shall Honeywell be liable for consequential, special, or indirect damages.**

While we provide application assistance personally, through our literature and the Honeywell web site, it is up to the customer to determine the suitability of the product in the application.

Specifications may change without notice. The information we supply is believed to be accurate and reliable as of this printing. However, we assume no responsibility for its use.

For more information about Sensing and Control products, visit www.honeywell.com/sensing or call +1-815-235-6847
Email inquiries to info.sc@honeywell.com

WARNING **PERSONAL INJURY**

- DO NOT USE these products as safety or emergency stop devices or in any other application where failure of the product could result in personal injury.

Failure to comply with these instructions could result in death or serious injury.

WARNING **MISUSE OF DOCUMENTATION**

- The information presented in this catalogue is for reference only. DO NOT USE this document as product installation information.
- Complete installation, operation and maintenance information is provided in the instructions supplied with each product.

Failure to comply with these instructions could result in death or serious injury.

Sensing and Control
Automation and Control Solutions
Honeywell
1985 Douglas Drive North
Golden Valley, MN 55422 USA
+1-815-235-6847
www.honeywell.com/sensing

008718-1-EN IL50 GLO
May 2008
Copyright © 2008 Honeywell International Inc. All rights reserved.

Honeywell