





Thru-beam Mode

Sensing Mode	Appearance	Supply Voltage	Output Mode	Part Number
Infrared 950nm	2m Cable 	10-30V DC	Emitter	<u>T30-T060MD-EY9C2L2</u>
			NPN	<u>T30-T060MN-CY9C4U2</u>
			PNP	<u>T30-T060MP-CY9C4U2</u>
			NPN/PNP	<u>T30-T060MD-CY9C5U2</u>
	Quick Disconnect 	10-30V DC (Euro Style)	Emitter (2-wire)	<u>T30-T060MD-EY9Q4LE</u>
			NPN	<u>T30-T060MN-CY9Q4UE</u>
			PNP	<u>T30-T060MP-CY9Q4UE</u>
			NPN/PNP	<u>T30-T060MD-CY9Q5UE</u>
Thru-beam Mode Sensing Distance: 60m	6" Pigtail 	10-30V DC (Euro Style)	Emitter	<u>T30-T060MD-EY9P4LE</u>
			NPN	<u>T30-T060MN-CY9P4UE</u>
			PNP	<u>T30-T060MP-CY9P4UE</u>
			NPN/PNP	<u>T30-T060MD-CY9P5UE</u>
	Quick Disconnect 	12-240V DC / 24-240V AC (Micro Style)	Emitter (2-wire)	<u>T30-T060MD-EY9Q4LE</u>
			Solid State Isolated Relay (4-wire)	<u>T30-T060MD-EY9Q4LE</u>
			Light-ON (2-wire)	<u>T30-T060MD-EY9Q4LE</u>
			Dark-ON (2-wire)	<u>T30-T060MD-EY9Q4LE</u>
6" Pigtail 	12-240V DC / 24-240V AC (Micro Style)	Emitter (2-wire)	<u>T30-T060MD-EY9P4LE</u>	
		Solid State Isolated Relay (4-wire)	<u>T30-T060MD-EY9P4LE</u>	
		Light-ON (2-wire)	<u>T30-T060MD-EY9P4LE</u>	
		Dark-ON (2-wire)	<u>T30-T060MD-EY9P4LE</u>	

X: T30 SERIES

Note:
 Coming Soon : Part numbers with underline
 In Preparation: Part numbers with a line through the middle

Specifications (DC)

Type		Thru-beam	Retroreflective (with polarizing filters)	Diffuse reflective (with background suppression)		
Item	Model No.	T30-T060Mx-xX9xxxx	T30-L6000x-xX6xxxx-PF	T30-D0200x-xX9xxxx-BS	T30-D0400x-xX9xxxx-BS	T30-D0600x-xX9xxxx-BS
Sensing Range		60m	6m (Note)	200mm	400mm	600mm
Sensing Object		Opaque object of ϕ 8mm or more	3-way mirror	White paper		
Hysteresis		—		20% or less of operation distance		
Supply Voltage		10 to 30V DC, Ripple P-P 10% or less				
Current Consumption		30mA or less				
Output		<NPN> output type NPN open-collector transistor <ul style="list-style-type: none"> • Applied voltage: 30V DC or less • Maximum sink current: 150mA • Voltage drop: 2.5V or less 		<PNP> output type PNP open-collector transistor <ul style="list-style-type: none"> • Applied voltage: 30V DC or less • Maximum sourcing current: 150mA • Voltage drop: 2.5V or less 		
Output Operation		Selectable either Light-ON Dark-ON by the control input wire				
Short-circuit Protection		Yes				
Reverse Polarity Protection		Yes				
Overload Current Protection		Yes				
Response Time		1.5ms				
Operation Indicator		Red LED (light up when the output is activated), Thru-beam sensor is provided it on the receiver				
Pollution Degree		3(Industrial environment)				
Protection		IP67(IEC)				
Ambient Temperature		-40°C to +70°C				
Maximum relative humidity		90% at 50°C (non-condensing)				
EMC		IEC 60947-5-2, Parts 7.2.6.1.2.3 or RFI>3V/m(in 30-1000MHz), EFT>1KV, ESD>4KV (contact)				
Voltage Withstand Ability		IEC 60947-5-2, Part 8.3.3.4 or 1500V AC for one min, between all supply terminals connected together and enclosure				
Insulation Resistance		>20M Ω , with 1500V AC megger between all supply terminals connected together and enclosure				
Vibration Resistance		IEC 60947-5-2, part 7.4.2 or 10-55HZ, 1.0mm amplitude in x, y and z directions for 30 min				
Shock Resistance		IEC 60947-5-2, part 7.4.1 or 30g, 11ms in x, y and z directions for six time each				
Emitting Element		Infrared LED (modulated)	Red LED (modulated)	Infrared LED (modulated)		
Housing Material		Plastic housing: PBT				
Cable		Standard length 2m, other length based on request.				
Connector		Euro-style connector(M12x1 thread)				
Pigtail Type		See Pigtail Series or our Cables & Connectors catalogue.				

Note: Used with RE-D82 (supplied with sensor) reflector.

Specifications (AC/DC)

Type		Thru-beam	Retroreflective (with polarizing filters)	Diffuse Mode (with background suppression)		
Item	Model No.	T30-T060MC-xX9xxxx	T30-L6000C-xX6xxxx-PF	T30-D0200C-xX9xxxx-BS	T30-D0400C-xX9xxxx-BS	T30-D0600C-xX9xxxx-BS
Sensing Range		60m	6m (Note)	200mm	400mm	600mm
Sensing Object		Opaque object of ϕ 8mm or more	3-way mirror	White paper		
Hysteresis		—			20% or less of operation distance	
Supply Voltage		12-240V DC / 24-240V AC				
Current Consumption		30mA at DC or 5mA at AC or less				
Output		Solid state Isolated Relay, 4-wire hookup; SPST solid-state switch, 2-wire hookup; • Applied voltage: 12 to 240V DC or 24 to 240V AC • Max. Load current: 300 mA; • Voltage drop: 3V or less				
Output Operation		Light or dark switching selectable via control wire (Solid state Isolated Relay), Selectable either Light-ON Dark-ON by type number (SPST Solid-state)				
Short-circuit Protection		Yes (Except Solid state Isolated Relay output)				
Overload Current Protection		Yes				
Response Time		15ms				
Operation Indicator		Red LED (light up when the output is activated), Thru-beam sensor is provided it on the receiver				
Pollution Degree		3 (Industrial environment)				
Protection		IP67 (IEC)				
Ambient Temperature		-40°C to +70°C				
Maximum relative humidity		90% at 50°C (non-condensing)				
EMC		IEC 60947-5-2, Parts 7.2.6.1.2.3 or RFI>3V/m (in 30-1000MHz), EFT>1KV, ESD>4KV (contact)				
Voltage Withstand Ability		IEC 60947-5-2, Part 8.3.3.4 or 1500V AC for one min, between all supply terminals connected together and enclosure				
Insulation Resistance		>20M Ω , with 1500V AC megger between all supply terminals connected together and enclosure				
Vibration Resistance		IEC 60947-5-2, part 7.4.2 or 10-55HZ, 1.0mm amplitude in x, y and z directions for 30 min				
Shock Resistance		IEC 60947-5-2, part 7.4.1 or 30g, 11ms in x, y and z directions for six time each				
Emitting Element		Infrared LED (modulated)	Red LED (modulated)	Infrared LED (modulated)		
Housing Material		Plastic housing: PBT				
Cable		Standard length 2m, other length based on request.				
Connector		Micro-style connector				
Pigtail Type		See Pigtail Series or our Cables & Connectors catalogue.				

Note: Used with RE-D82 (supplied with sensor) reflector.

Sensing Characteristics (Typical)

Opposed Mode (Sn=60m)

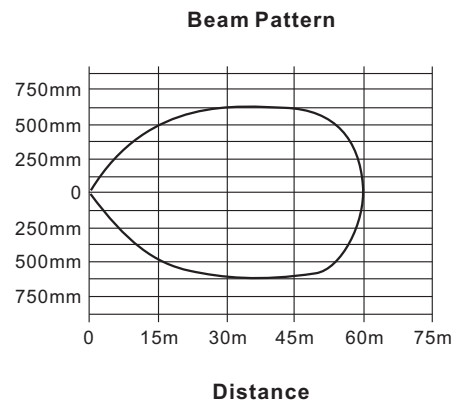
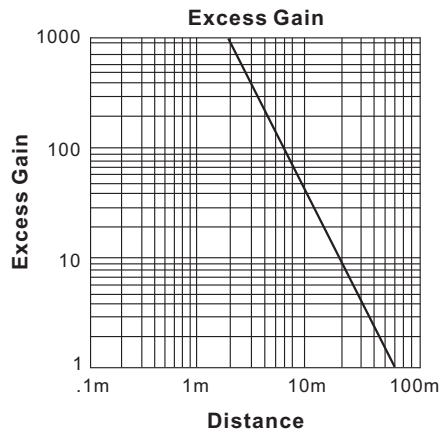

Polarized Retroreflective Mode (Sn=6 m)

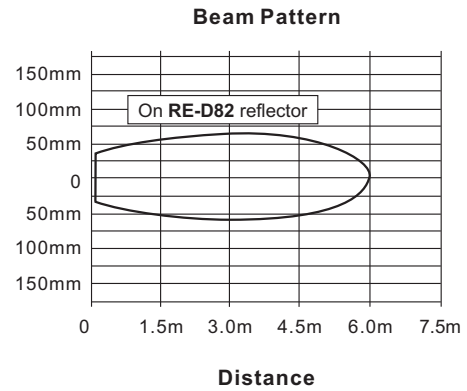
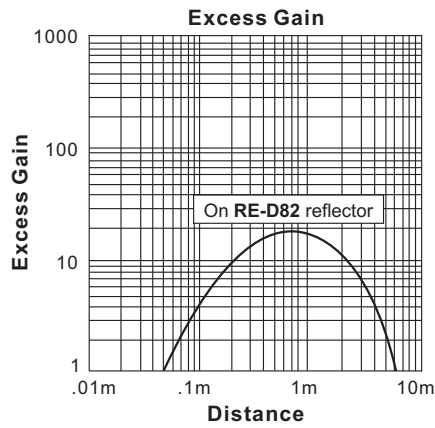

Diffuse Mode with Background Suppression (Sn=200/400/600mm)

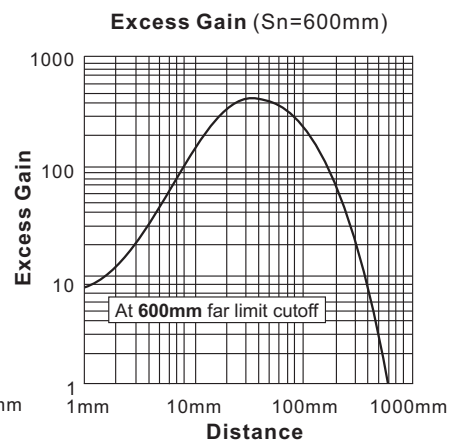
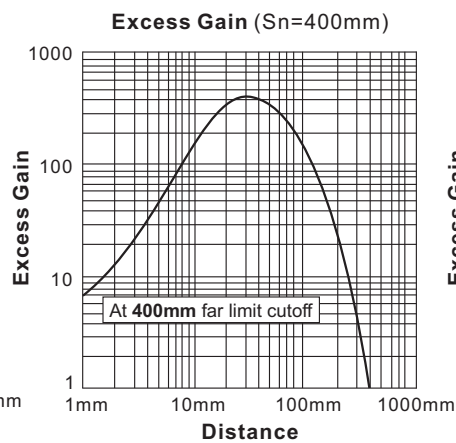
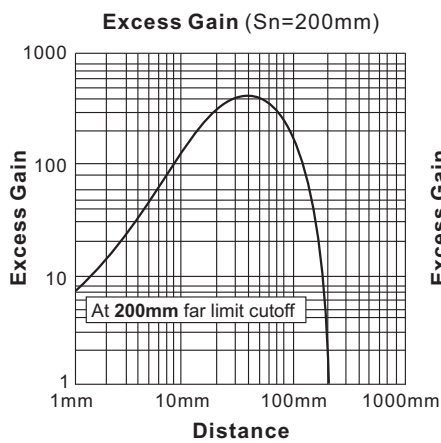

X : T30 SERIES

Connection Diagrams (DC)

NPN output type

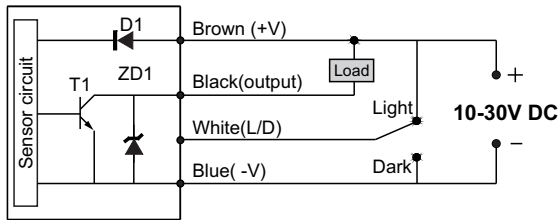

Symbol D1: Reverse polarity protection diode
 ZD1: Surge absorption zener diode
 T1: NPN output transistor

Connector pin position

Euro-style

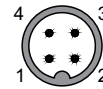

1. Brown (+)
2. White (Light/Dark control)
3. Blue (-)
4. Black (Output)

PNP output type

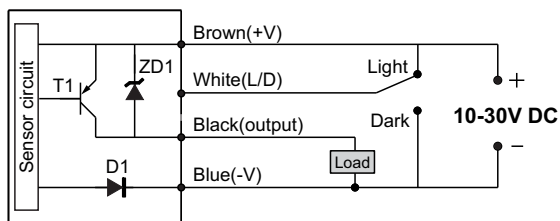

Symbol D1: Reverse polarity protection diode
 ZD1: Surge absorption zener diode
 T1: PNP output transistor

Connector pin position

Euro-style

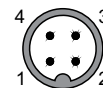

1. Brown (+)
2. White (Light/Dark control)
3. Blue (-)
4. Black (Output)

X: T30 SERIES

NPN/PNP output type

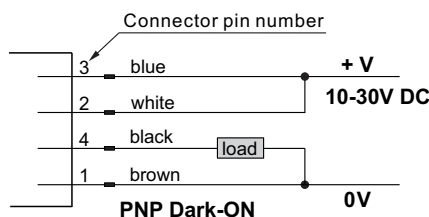
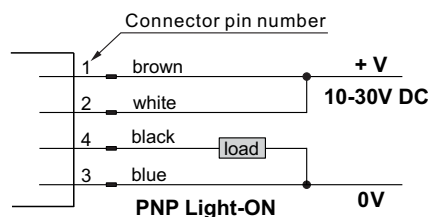
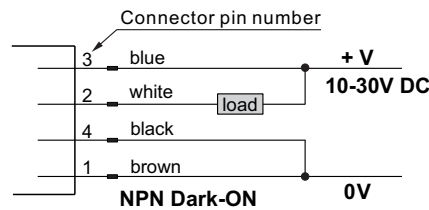
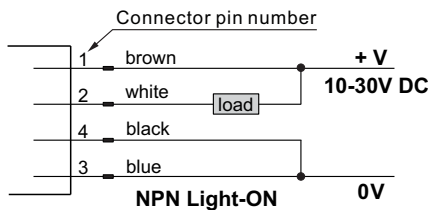

Connector pin position

Euro-style

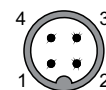

1. Brown
2. White
3. Blue
4. Black

Emitter of Thru-beam Mode

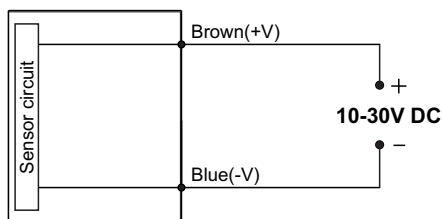

Connector pin position

Euro-style

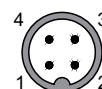

1. Brown (+)
2. Not used
3. Blue (-)
4. Not used

Connection Diagrams (AC/DC)

SPST Solid State output

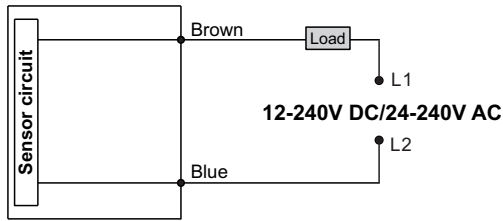

Connector pin position

Micro-style

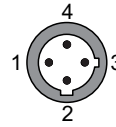

- 1.Red/black(L1)
- 2.Red/white (L2)
- 3.Not used
- 4.Not used

Solid State Isolated Relay

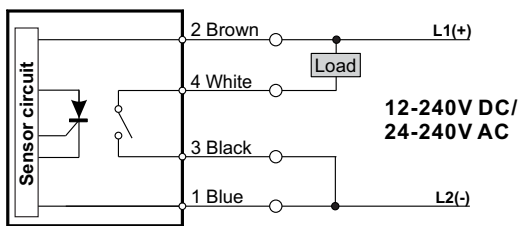

Connector pin position

Micro-style

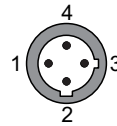

- 1.Red/black(L2)
- 2.Red/white (L1)
- 3.Red (Output)
- 4.Green (Output)

OR

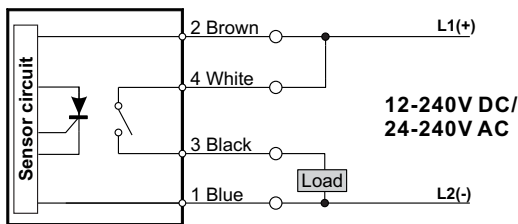

Emitter of Thru-beam Mode

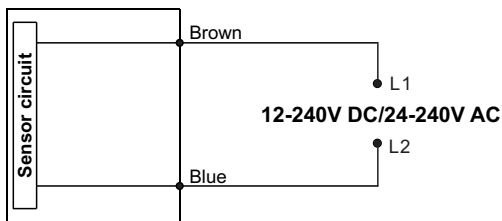

Connector pin position

Micro-style

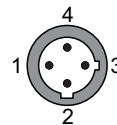

- 1.Red/black(L1)
- 2.Red/white (L2)
- 3.Not used
- 4.Not used

X: T30 SERIES

Dimensions (Unit: mm)

Sensor Type

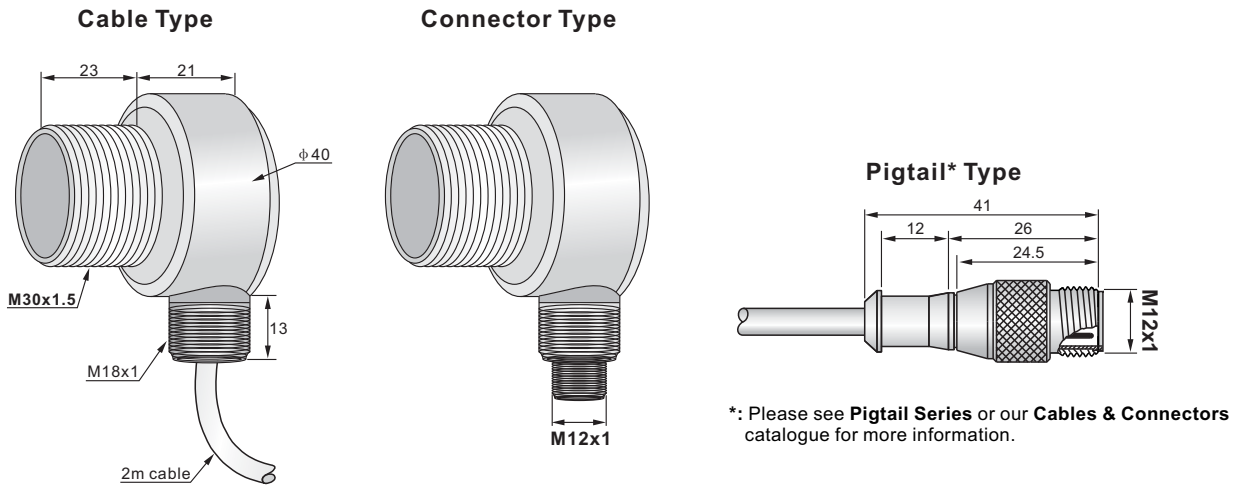

Mounting Brackets *

MB-4630 (optional)

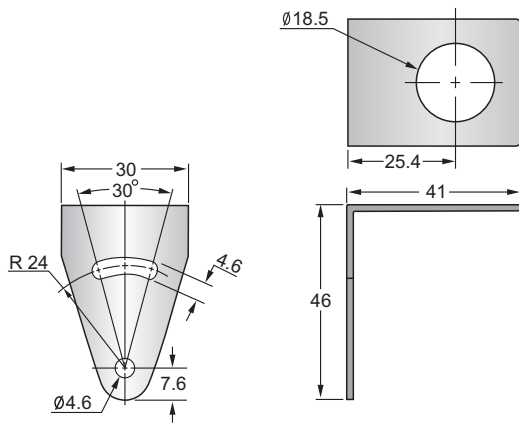

MB-6961 (optional)

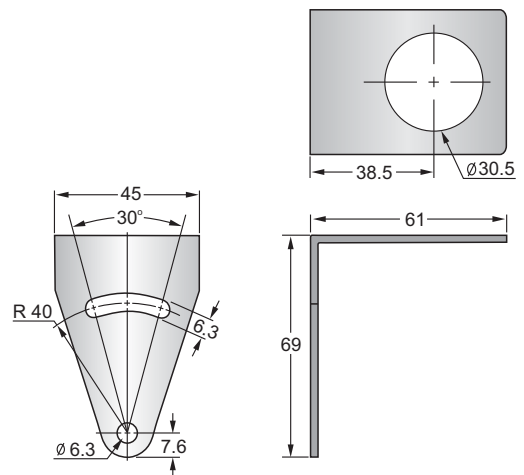

MB-6356 (optional)

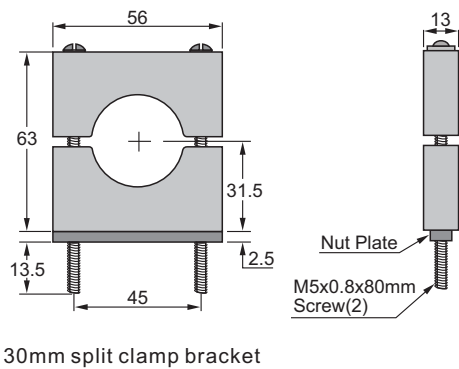

MB-6658 (optional)

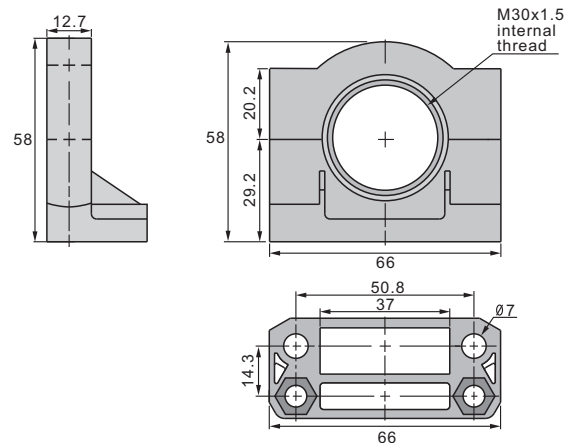

*: Please see **Accessories** (Universal Mounting Brackets Series).

Mounting Bracket to Provide 360° Rotation